

Design and Fabrication of Intake System

Mr. Mudigoudar Shashantgouda ^{*1}, Mr. Shubham Ghorpade ^{*2}, Mr. Sahil Londhe ^{*3}, Mr. Adepu Shivkumar ^{#4}, Prof. Chetan Thakur ^{*5}

^{#1,2,3,4} Bachelor of Engineering Students, Department of Automobile Engineering, Saraswati College Of Engineering, Kharghar, Navi-Mumbai, Maharashtra, India

^{*5} Professor, Department of Automobile Engineering, Saraswati College Of Engineering, Kharghar, Navi-Mumbai, Maharashtra, India

Abstract - This project is about Design and Fabrication of an air Intake system which is developed as per the rules for the Formula Student Vehicle. It is done primarily to provide maximum airflow to the engine. The research included in this paper is limited to designing a CAD model of an Air Intake system with the help of using Solidworks software. The parameters have been set as per the rulebook by Formula Student competitions to be held. This paper focuses on an optimized intake system for a (KTM) 390cc Single cylinder SI engine, required to work under normal conditions.

Keywords: FSAE, Intake System, Venturi, Restrictor, Plenum, Runner, CAD

I. INTRODUCTION

The intake system is one of the engine's most important subsystems. The main purpose of the intake manifold is to direct air from the throttle body into the intake ports. The volume of air going into the engine must be maximized to boost the power output. However, the following guidelines must be followed while designing an FSAE vehicle's air intake system,

- The engine utilized must be a four-stroke spark ignition engine with a displacement of no more than 610 cm³.
- The intake system must only induct air through a single circular constraint positioned after the throttle and before the engine. For gasoline-powered vehicles, the constraint diameter must be 20mm.
- None of the engine's Intake components should extend beyond the vehicle's surface envelope.
- The maximum allowable internal diameter of the intake runner system between the restrictor and throttle body is 60 mm diameter, or the equivalent area of 2827 mm² if non-circular.

Therefore, it is essential to design a quality intake system to lower pressure losses caused by the restrictor and achieve high mass flow rates and even air distribution at runner, which will increase the engine's efficiency.

An effective intake manifold design might offer significant performance gains over a less ideal one. The intake manifold must meet the following design objectives:

- ✓ Minimal airflow resistance.
- ✓ High air velocity for a specified flow rate.
- ✓ Throughout, there is excellent fuel and air distribution.

Since the restrictor, plenum, and runner of the manifold play a major role in the design of the FSAE vehicle's intake system, teams typically attempt,

- To improve the design of convergent-divergent restrictor.
- To optimize the geometry of the plenum for minimum flow resistance and maximum air flow velocity
- To get the best possible plenum volume.
- To achieve the best possible runner length and diameter.

II. METHODOLOGY

The procedure for designing an intake system starts with selecting the engine to be used by taking into consideration the budget, the optimal power-to-weight ratio, the accessibility of spare parts for better engine maintenance, and the condition that the engine's displacement be less than 610 cc. As a result, we decided to go with the 373.2 cc KTM Duke 390 engine.

The project is thereafter proceeded in the following manner:

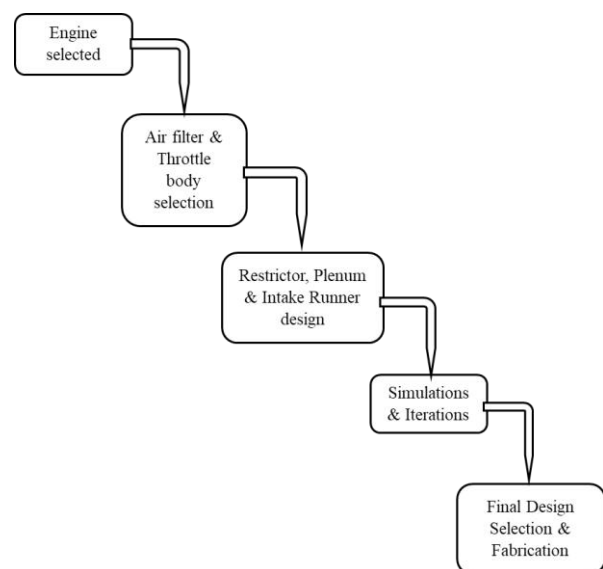

Figure 1: Project Flow

III. DESIGN & ANALYSIS

A. Guidelines

1. The engine utilized must be a four-stroke spark ignition engine with a displacement of no more than 610 cm³.
2. The intake system must only induct air through a single circular constraint positioned after the throttle body and before the engine. For gasoline-powered vehicles, the constraint diameter must be 20 mm.
3. None of the engine's Intake components should extend beyond the vehicle's surface envelope.
4. The maximum allowable internal diameter of the intake runner system is 60 mm diameter, or the equivalent area of 2827 mm² if non-circular.

B. Restrictor (Venturi)

Since the throat diameter is 20 mm in accordance with the guideline, the mass flow rate is constant for all restrictors built and is therefore 0.0743 kg/s.

Formula for calculating Mass Flow rate is:

$$\dot{m} = (A \times P_t \div \sqrt{T_t}) \times \sqrt{(\gamma \div R)} \times M (1 + ((\gamma - 1) \div 2) M^2)^{-((\gamma+1) \div 2(\gamma-1))}$$

Here,

\dot{m} = Mass Flow Rate

A = Cross-sectional Area = 0.00031415 mm²

P_t = Pressure in Throat (101325 Pa)

T_t = Temperature in Throat (300K)

R = Gas constant = 287 kJ/kg K

M = Mach number = 1

γ = Specific heat ratio = Cp/Cv = 1.4

where,

C_p = Specific Heat at Constant pressure

C_v = Specific Heat at Constant volume

Therefore,

$$\dot{m} = ((0.00031415 \times 101325) / \sqrt{300}) \times \sqrt{(1.4/287)} \times 1 (1 + ((1.4 - 1) \div 2) 1^2)^{-((1.4 + 1) \div 2(1.4 - 1))}$$

$$\dot{m} = 0,0743 \text{ kg/s}$$

We designed and analysed 4 different models of Venturi restrictor keeping diverging angle of 6° as one constant parameter.

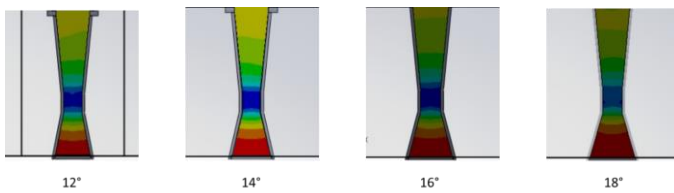

Figure 2: Venturi with different Converging angle

1. Venturi Selection Criteria

1. The function of Venturi is to restrict the fresh charge of the air and increase the air velocity at the divergent part.
2. Pressure should be dropped to the most minimal level at throat section.
3. Velocity should reach to the highest level at the end of the throat.
4. No flow separation should take place.

2. Simulations on Venturi with Converging Angle of 12°

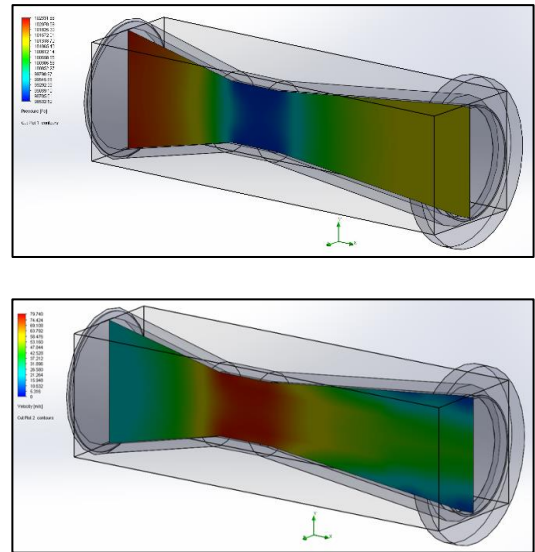

Figure 3: Pressure & Velocity Simulation (12°)

3. Simulations on Venturi with Converging Angle of 14°

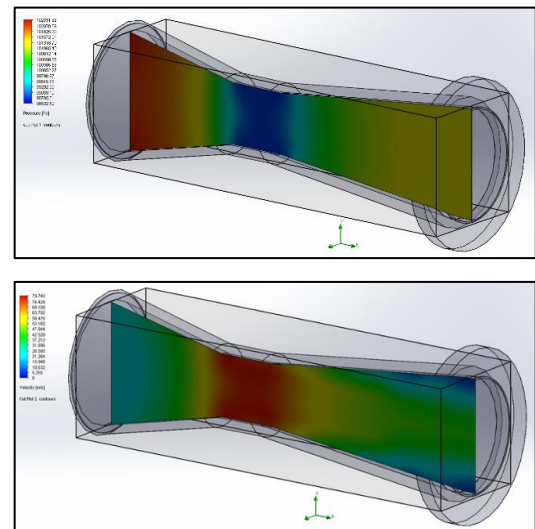

Figure 4: Pressure & Velocity Simulation (14°)

4. Simulations on Venturi with Converging Angle of 16°

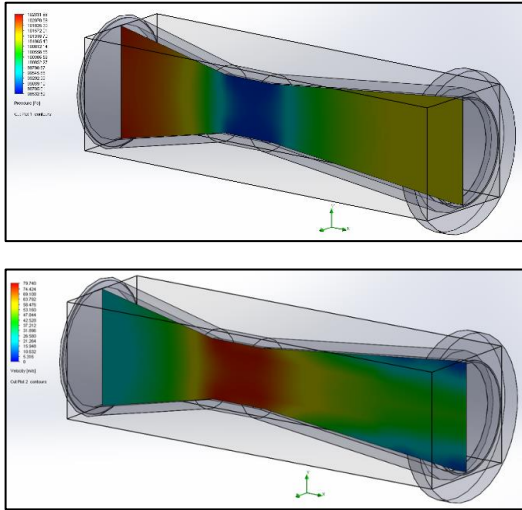

Figure 5: Pressure & Velocity Simulation (16°)

5. Simulations on Venturi with Converging Angle of 18°

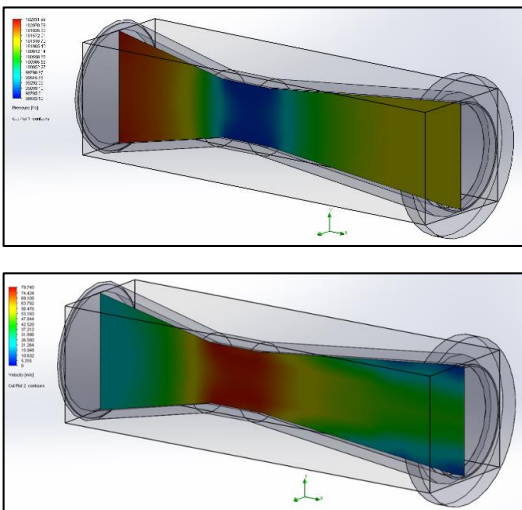

Figure 6: Pressure & Velocity Simulation (18°)

Diverging Angle	Converging Angle	At throat	
		Minimum Pressure (Pa)	Maximum Velocity (m/s)
6°	12°	98532.52	79.7
	14°	97191.52	96
	16°	97089.75	95.6
	18°	92766.25	131.252

Table 1. Venturi Simulation Results

6. Observations

1. The pressure at throat is dropped at the most minimum level in this type of venturi. We get the reading as, 92766.25 Pa.
2. The pressure is gradually increasing towards the end of the diverging part of venturi.
3. Velocity attained at the throat portion of this venturi tube is highest of all other three tested venturis which is 131.252 m/s.
4. Flow separation is minimum. As we can see the blue patch near the diverging end (blue patch signifies turbulent air & flow separation) of venturi is the most minimum of all.
5. So, it is concluded that as we increase the convergence angle the values are getting near the acceptable range. So, this venturi is selected

C. Plenum

For plenum we considered 4 different shapes of volume approximately 1.2-1.4 L which is almost 3 to 4 times greater than the engine displacement to ensure efficient amount of air entering the intake valve of the Engine.

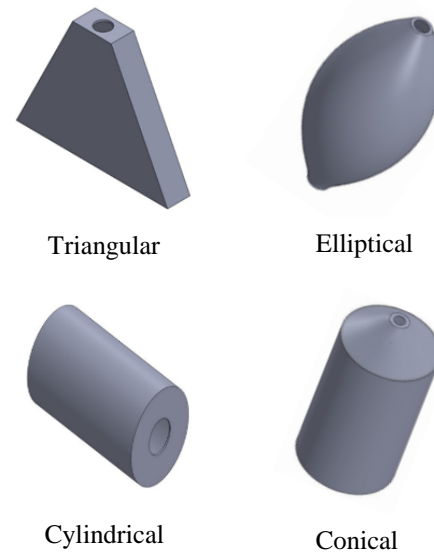

Figure 7: Intake Plenum CAD Models

1. Plenum Selection Criteria

1. Volume of the plenum chamber is about 3 to 4 times of the engine displacement.
2. Design of Plenum chamber should be such that it cannot exceed the permissible envelope of the chassis of the car.
3. The pressure of the air inside must not exert more pressure on the walls of plenum.

2. Simulations on Elliptical Plenum

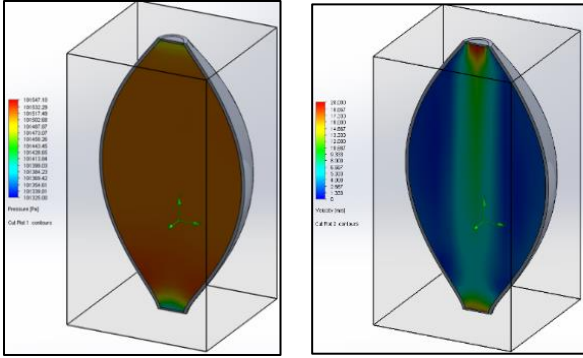

Figure 8: Pressure & Velocity Simulation (Elliptical)

3. Simulations on Triangular Plenum

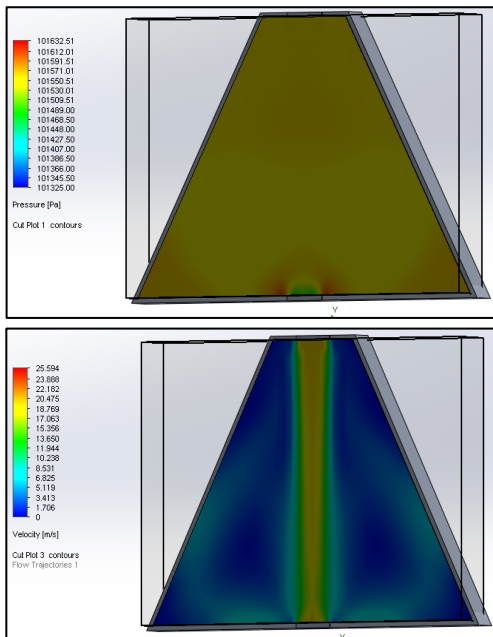

Figure 9: Pressure & Velocity Simulation (Triangular)

4. Simulations on Conical Plenum

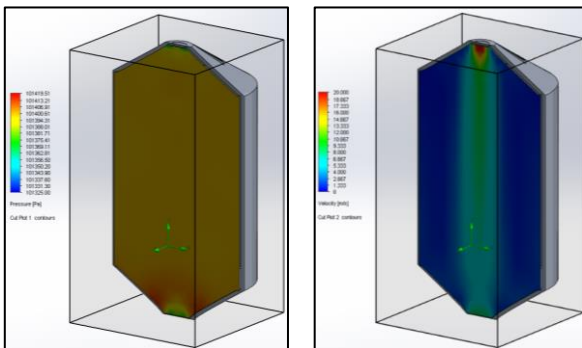

Figure 10: Pressure & Velocity Simulation (Conical)

5. Simulations on Cylindrical Plenum

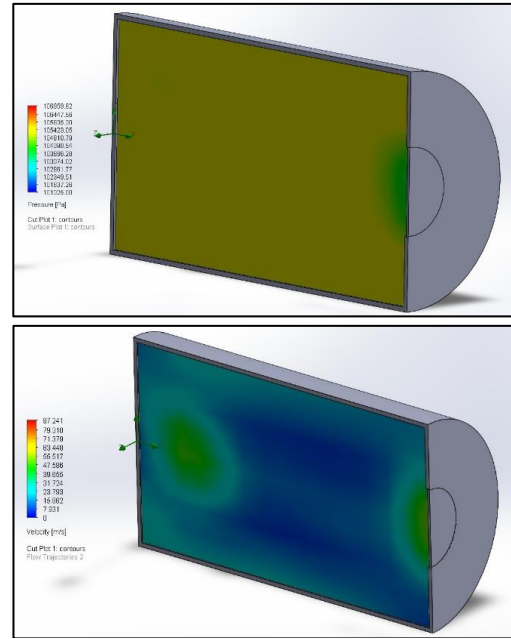

Figure 11: Pressure & Velocity Simulation (Cylindrical)

6. Observations

1. The air pressure on the walls of both the Cylindrical & the conical plenum are quite lower than the other two.
2. From packaging point of view the cylindrical plenum will take less space and will be easier to fabricate and install as compared to other plenums.
3. Vortices are formed in triangular plenum, which hinder maximum airflow.
4. Therefore, cylindrical plenum is selected.

D. Intake Runner

The Runner of the Intake System is a cylindrical Pipe connecting Plenum to the Intake Valve of the Engine.

Calculation for Runner Length:

The runner length is calculated using the Induction wave theory,

$$L = \frac{EVCD \times 0.25 \times V \times 2}{rpm \times RV} - 0.5 \times D$$

Where,

EVCD = Effective valve closed duration

V = speed of sound, ft/s

Rpm = Revolutions per minute

RV = Reflective value

D = Runner Diameter = 42mm = 1.653 inches (same as the engine inlet port)

ECD = Effective cam duration

In the KTM RC 390 engine the Intake valves opens 2 degrees Before Top Dead Centre (BTDC) and Intake valves closes 44 degrees After Top Dead Centre (ATDC)

$$ECD = 180^\circ + 2^\circ + 44^\circ = 226^\circ$$

$$EVC D = 720^\circ - (ECD + 20^\circ) = 720^\circ - 226^\circ + 20^\circ = 514^\circ$$

Therefore, from the formula the Length of runner,

$$L = \frac{514 \times 0.25 \times 1152 \times 2}{6500 \times 4} - 0.5 \times 1.653 = 10.56 \text{ inches}$$

$$L = 268.24 \text{ mm}$$

E. Assembly Design



Figure 12: Intake System Assembly

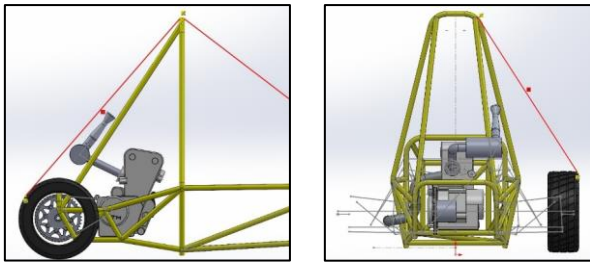

Figure 13: Side & Rear-View Surface Envelope



Figure 14: Manufactured Parts

IV. CONCLUSION

1. The overall Intake System is developed with respect to design as well as fabrication point of view.
2. While proceeding with the design, the accommodation of Intake System within the Envelope has been considered as per the FSAE rules.
3. Another important thing was made sure that no member or part of Intake System interferes with any of the other members of the vehicle's rear which includes components as well.
4. For convenient manufacturing and better positioning for proper flow of air, among different plenum shapes considered, a cylindrical shaped plenum is selected after looking into the analysis that was carried out.
5. The optimization of maximum mass flow rate of air along with minimum loss of pressure through the

Venturi lowering the possibility of flow separation is achieved with the convergence of 18 degrees and divergence of 6 degrees.

6. The runner pipe is inclined at 45° from the origin of Plenum to allow the airflow more effectively.
7. Overall 2 throttle bodies are used i.e. one at the top of Venturi, and the other one below the Plenum before the Intake valve of Engine. An air filter is mounted at the top of upper throttle body to avoid dust particles and debris entering the intake valve.

V. REFERENCES

1. Shubhamkumar Mangukiya, Mr. Ripen Shah, Mr. Mazar Shaikh, "Enhancing the performance of single cylinder motorcycle engine for formula student vehicle by optimizing intake and exhaust system", (JETIR July 2018, Volume 5, Issue 7) ISSN-2349-5162
2. Awanish Pratap Singh, "Intake Manifold Design Using Computational Fluid Dynamics" (ResearchGate 2016)
3. P Sawant, S Bari, "Combined effects of variable intake manifold length, Variable Valve Timing and duration on the performance of an internal combustion engine", (November 2017), IMECE2017-70470
4. B.Praveen Kumar, Ch.Rajkumar, D.Phanindhar, B.Srinivas Reddy, Ch. Vineeth Sai, "Modeling, Analysis and Fabrication of Intake System FSAE", (IJIRSET, Volume 9, Issue 5, May 2020), e-ISSN: 2319-8753, p-ISSN: 2320-6710
5. Pranav Anil Shinde, "Research and optimization of intake restrictor for Formula SAE car engine", (IJSRP, Volume 4, Issue 4, April 2014) ISSN 2250-3153
6. Siddhant Kadam, "Air Intake System For Formula Student Vehicle", (IJEDR, Year 2020, Volume 8, Issue 2) ISSN: 2321-9939
7. S S Sawant, P N Gurav, P S Nivalkar, P M Sawant, Dr. S N Waghmare, "Design And Fabrication of Air Intake For FSAE Race Car", (2017), ISSN [ONLINE]: 2395-1052
8. Shivam Garg, Nikhil Keswani, Rishav Sharma, "Validation and Designing of Intake System for 1 Cylinder SI Engine in Formula Student Racing Vehicle", (IRJEET Volume – 01, Issue – 01, March – 2020)
9. Sudipta Karmakar, Rohan Rai, Sharat Anand, Shayak Choudhary, "Performance Analysis of Multiple Intake Design Methodologies for an open Wheel Race Car Vehicle using Different Simulations", (IJERT, Volume 9, Issue 07, July 2020), ISSN: 2278-0181
10. Len Hamilton, "The Effects of Intake Plenum Volume on the Performance of a Small Naturally Aspirated Restricted Engine", (ResearchGate 2009).
11. <https://research.vit.ac.in/publication/design-and-development-of-a-restricted-intake/figure/figure-17-exploded-view-of-intake-manifold.png>