

Non Conventional Energy Resources

Dr. Pijush Kanti Bhattacharjee

Professor & Dean, Department of Electronics & Communication Engineering,
Guru Nanak Institute of Technology, Kolkata, India

1. Introduction

At present it is indispensable to find out the renewable or the harvesting electricity (electrical power) sources for domestic as well as commercial purposes. At present in world, more than 13% of people and in India 14% of people are not getting electricity from the grid in their daily life. For electricity such as lighting, cooking, moderate machine operating etc., people are extremely depending on oil like kerosene, diesel, petrol, bio-oils, gas and other bio-materials like trees, extracts of food grains etc. These firing of oils or bio-materials cause extreme pollution to nature. Secondly our conventional power generating station like thermal electric power plants, hydro electric power plants, nuclear electric power plants etc. are causing heavy pollution to nature and living world. Dust, ashes and disposals (outcome) of these electric power stations are extremely harmful to the living world, the radioactive ashes of the nuclear electric power plants are not only rejecting immediate harmful materials, but it has a long lasting action also, since it emits radioactive radiations (α , β , γ -rays) for a long time. Coal and other burning materials ashes, numerous poisonous gases like CO, CO₂, SO₂, methane and hydrocarbons etc. are the disposals of thermal electric power stations which are the most popular and highly electric power generation method adopted throughout the world at present. Thus the thermal electric power plants are causing extreme pollution to our mankind and nature. Lot of diseases with handicapped effect is the fruit of these electric power plants.

Also natural resources like coal, oil, radioactive materials etc. will come to shortage stage or an end in near future. The other electric power generating systems like hydro electricity power plants cannot afford much power, although these cause less pollution. Thus it needs urgent invention to go for non-conventional or renewable energy resources. The main advantage of the renewable electric power generation systems are that no carbon (CO, CO₂, CH₄, hydrocarbon etc.) emission in the atmosphere takes place, i.e., environmental pollution is nil, and no raw materials (coal, nuclear fuel etc.) are exhausted.

The most popular non-conventional electric power resources are solar energy electric power generation system which converts solar energy or solar heat to electricity. Solar electric power system has some drawback also, that is, it cannot generate electric power in cloudy or rainy days. Therefore, people using this solar system have to remain without electricity (power) after battery or accumulator circuit gets discharged during the rainy season or the sun's shortcomings, since it is totally depended on appearance of the sun in the sky. Moreover, it has very much limited capacity. We cannot capture all available solar energy in a place, because it is urgently required in all other fields also, e.g., biological body or health care, agriculture, chemical reactions, industries etc. Therefore, we have to search all other renewable electrical power sources from the

nature such as rains water, wind flow, charged cloud, lightning, and thunder energies which can be easily converted as a good and reliable electrical energy source. By converting the natural energies into electricity, the natural balance and harmony is maintained.

2. Solar Electric Power Generation System

The sun is a continuous fusion reactor in which hydrogen combines to form helium and evolving huge amount of heat energy as per the following reaction:

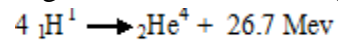

This heat energy from the sun is emitted in the universe and the earth by transmission of tiny bundles of energy particles called photons which move with finite speed (almost speed of light). When photons strike an atom, they interact with the electrons by transferring their energy and hence they are absorbed. The Sun rays are composing of different wavelength spectrum of electromagnetic waves from the low to the very high ranges, but UV (ultra-violet) radiation, other low and very high range wavelength radiations are absorbed by ozone, oxygen, nitrogen, water vapors etc. lying above the earth's atmosphere. Thus the sun rays consist of electromagnetic waves having wavelength (λ) radiation between 0.29 μm to 2.3 μm (approximately).

A solar cell consists of a basic element, named photovoltaic (PV) generator, usually as doped semiconductor materials, e.g., photodiode, phototransistor etc. Photovoltaic (e.m.f.) generation is caused by the sun light radiation, i.e., the photons absorption that separate positive and negative charge carriers in the absorbing semiconductor materials. These charges, constitute an electric voltage, can afford a current for use in external circuit or load. Different types of solar cell materials are single crystal, polycrystalline and amorphous silicon and compound of thin film semiconductor materials. Variety of semiconductor compounds such as CuInSe_2 , CdS , CdTe , Cu_2S , InP etc. are used to manufacture thin film solar cells. The combinations of different band gap (E_g) materials lead to photovoltaic generators of much higher efficiencies.

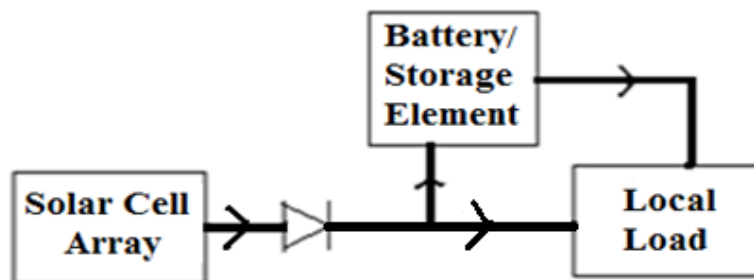

Fig. 1. Basic solar (photovoltaic) electric power generation system.

The solar electric power generation system is planned accordingly Fig. 1. The solar cell array or panel consists of an appropriate number of solar cell modules connected in series or parallel to

provide the required voltage and current. Storage batteries as shown in Fig. 1 provide the backup power during no sun shine period by storing the excess electric power or some portion of electric power from the solar arrays. This solar electric power generating system is used for private power consumption, meteorological stations, Radio or TV relay stations, entertainment places like cinema, hotel, restaurant, villages and islands. In Fig. 2, the complete solar power system is delineated.

Components of Solar Power Plant

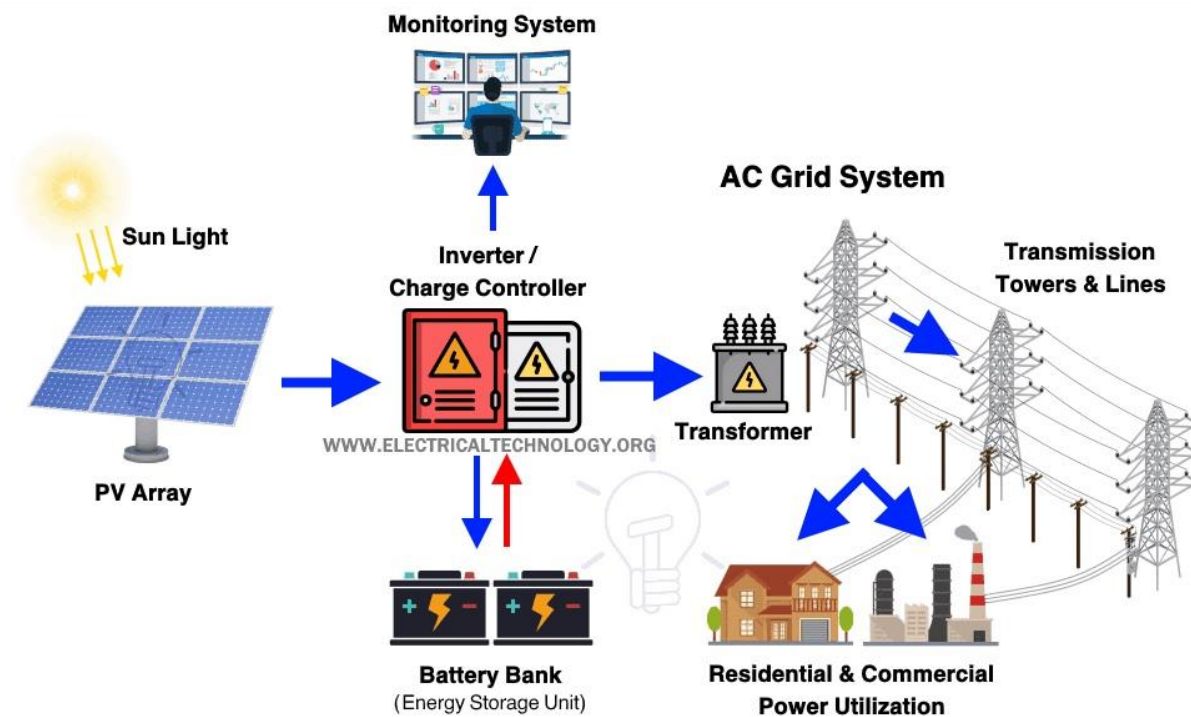

Fig. 2. Solar power plant system.

The small size solar array or panels are fitted in addition on the roof or the earth to the wall, the sunsets, the balcony etc. of a building or a structure, such that full solar energy falling on the building can be utilized. Making this type arrangement, inside of the building will remain in very moderate temperature even in hot summer times. Excess solar power can be supplied to the existing grid for earning revenue.

3. Rains Electric Power Generation System

In this system the energy of water is utilized to drive the turbine which in turn runs the power generator to produce electricity. Rains falling on the earth's surface have potential energy relative to the oceans level. This potential energy is converted to shaft work or rotate, in which the water falls through an appreciable vertical distance (minimum 9 feet). The hydraulic power obtained from the rains water is thus a naturally available renewable energy source. It is expressed as $P = gpQH$ watt, where P is the hydraulic power in watt, g is 9.81 m/s^2 (the

acceleration due to gravity), ρ is the water density ($\rho = 1000 \text{ kg/m}^3$), Q is the flow or discharge in m^3/s and H is the height of fall of water in meter. The electrical energy produce in kWh is written like this, $E = 9.81 \times 1000 \times Q \times H \times \eta \times t \text{ kWh}$. Here t is the operating time in hours and η is the efficiency of the turbine generator assembly which varies 0.5 to 0.9. The rains power developed thus depends on Quantity (Q) and Head (H) of water.

(A)

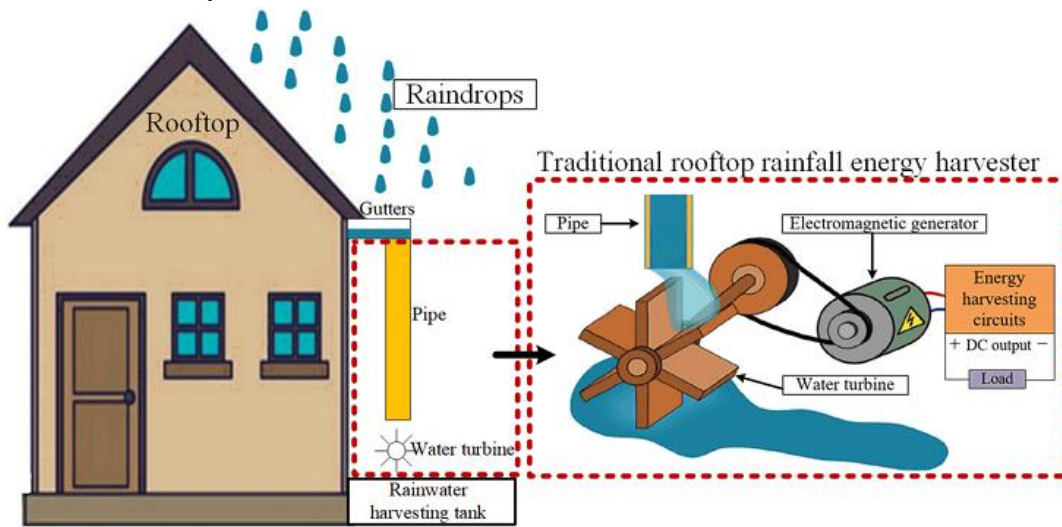

(B)

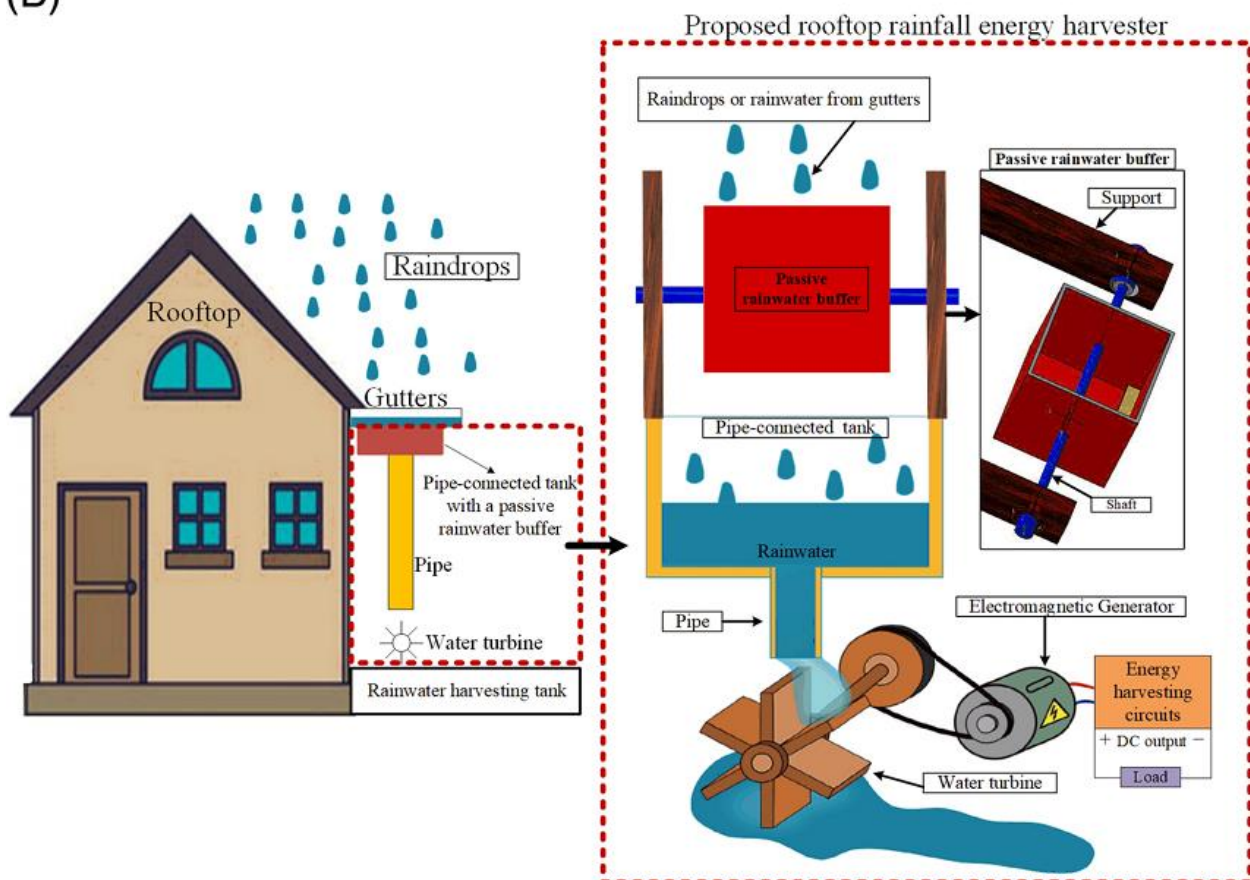

Fig. 3. Rain water electric power generation system.

The rains power generation system is shown in Fig. 3 which is the similar that of the solar system as shown in Fig. 1 and Fig. 2. The only difference is that in place of the solar array, we apply the rains power generator having turbine assembly. In rainy times, the rains water are collected in a reservoir or roof top which are kept at a certain height like the height of a building or on a hill or above usual water tank etc., this collected water is allowed to fall from that height (at least 9 feet to 15 feet or more) to the blades of small turbine whose shaft fed to a dynamo (small type). The current, develops in the dynamo due to rotation of light turbine blades, is supplied to the local load as well as charging the batteries or storing in the accumulator circuit which consists of capacitors and inductors or integrated circuits (ICs) etc. While the sun appears, the local load and the batteries can be fed by the solar panel. Therefore, the electric power from these renewable energy sources like the solar or the rains is available all times in a day, also in the night period when the rain falls. This power generation system does not produce any kind of environmental pollution.

4. Wind Electric Power Generation System

The wind energy is a renewable source of energy. It is used to run a windmill which in turn drives a wind generator or a wind turbine to produce electricity. Practically it is observed that the flexible three blades propeller about 35 m in diameter, in a 60 km/hr wind pressure with a rotation speed of 47 rpm produce maximum power 12 MW. For small wind power generation system, multiple blade type (3 to 5 number blades) or Darrieus type (Curved Blade 3 to 5 numbers) is highly suitable. The main drawback of this system is that as the wind speed or velocity is not constant with respect to time, i.e., fluctuating; hence the electric power thus obtained is also not having predetermined value like varying nature.

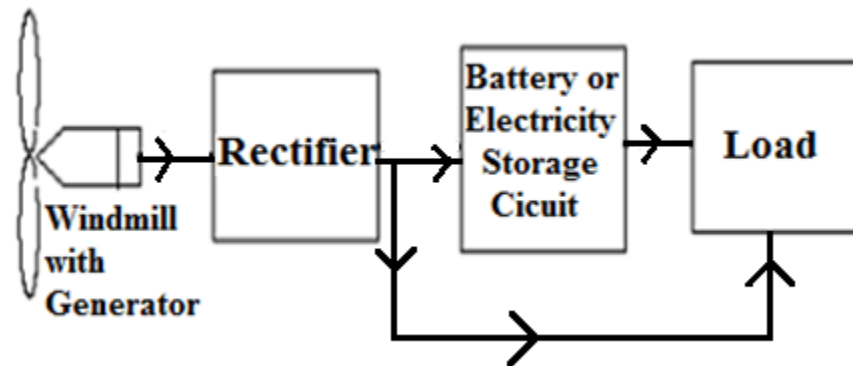

Fig. 4. Block diagram of windmill electric power generation system.



Fig. 5. A typical wind electric power generation network

Thus it is better to feed the wind electricity to the battery or any power storage device, i.e., accumulator circuit which supply to the load later on accordingly, rather directly supply to the load as shown in Fig. 4. In wind electric power generation system, the electric power increases in proportion to the cube of the wind speed. Thus it is highly enhanced in rainy and stormy period when the wind speed is excellent to produce electricity. This electric power generation system is pollution free pure ecologically balanced one. Picture of a typical wind electric power network is placed under Fig. 5.

Small size wind mill with generator either horizontal or vertical or inclined with a certain angled blades can be placed on the wall, the sunsets etc. of a building for utilizing the maximum power of wind in all directions. Making this event, inside of the building will remain under sweet temperature with smooth environment.

There are other renewable electric power generation systems such as Charged Cloud, Lightning, Thunder electric power generation systems and thereafter integrating all types of renewable energies, which are described below. In Future Lightning will be used as renewable electric source, following circuits are designed to get electricity from cloud and lightning.

5. Introduction of Lightning and Cloud Energy

In this proposed electric power generation systems, the static electric charge containing a lightning or before lightning by a charged cloud are stored. There are several ways in which a charged cloud or a lightning energy can be stored as electrical energy, and subsequently it can use as a source for electric supply. Especially this huge amount of electrical energy obtained from a charged cloud or a lightning is a remarkable green electrical energy sources with the least cost for production, transmission and maintenance etc. An average lightning carries current about 50 kA, charge 30 coulombs and energy 1 GJ. Lightning is accompanied by thunder which is high intensity deep sound. Therefore, thunder (loud sound) energy can be converted to electricity also. This is described elaborately in different procedures below. A picture of lightning with thundering is shown in Fig. 6.



Fig. 6. Lightning with Thunderstorm.

6. Charged Cloud, Lightning and Thunder Energies Act as Electric Power Source

It is seen that cause of rains, lightning and thunder is clouds that carry the charge either positive or negative nature. Today it is the subject of scientific research that how a cloud becomes statically charged? We observe that the lightning, which creates by the collision of charged clouds in the sky, falls on the earth causing huge destruction to living and non-living properties. Generally the clouds are consisting of water vapors with other chemical atoms in much cooled ice stage moving in the sky. Gradually the clouds collect electrostatic charge either positive or negative by frictional collisions among the tiny particles of ice, water droplets and other materials, different radiations with various frequencies in the sky, such as, cosmic rays, ultraviolet rays, electromagnetic waves etc. Whenever two or more clouds having different charges like positively and negatively charged clouds collide with each other, then the heavy spark generates which is named as lightning followed with thunder, clearly explained in Fig. 7. The heat generated in the clouds by this collision produce rains, i.e., ice of the clouds are melted by this frictional and electrical heat, and accordingly rains appear as per humidity present in the surrounding air. Again the remaining clouds after collision possess very less charge, because most of the charges in the clouds are neutralized. It is seen that in hilly areas, lightning occurs very less, because the charged clouds strike the hill surface and the charge of the clouds are grounded or neutralized.

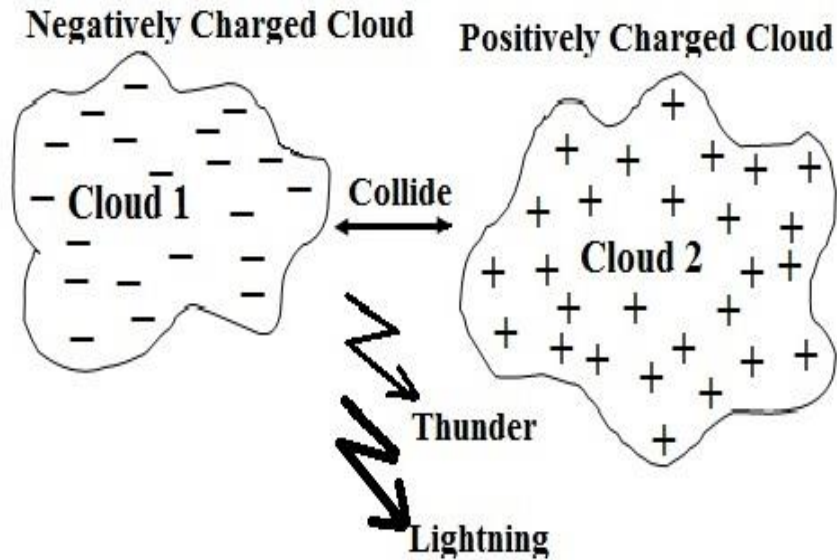

Fig. 7. Collision of the clouds.

The intensity of the lightning and the thunder depends on so many parameters (factors) of the colliding clouds like charge carrying, mass, velocity, frictional area, different elements and compounds present etc. Therefore, the clouds hold electrostatic charge either positive (+) charge or negative (-) charge, i.e., voltage. There are two types of lightning known as positive lightning and negative lightning. When the more amounts of positive charged cloud strikes with the less amounts of negative charged cloud, then positive lightning happens; and when the more amounts of negative charged cloud collides with the less amounts of positive charged cloud, negative lightning falls. Positive lightning is often considered more dangerous than negative lightning, because its electrical field is stronger. In case of positive lightning the flash duration is typically longer, and its peak charge can be much greater (like 10 times) than a negative strike. Also lightning can have 100 million to 1 billion volts and contain billion of watts. Thus it assures a giant source of electrical energy.

Therefore, these charged clouds are trying to release the charge by hook or crook. Also when this charge on the clouds is sufficiently high enough to break down the insulation of air, this heavy electrical energy (charge) drops to the earth as lightning and thunder. Whenever this electrostatic charge on the clouds is not released, the clouds hold the charge moving hither and thither with charged condition either positively charged or negatively charged. This phenomenon is called wait state of the charged cloud.

7. First Technique for Charged Cloud and Lightning Electric Power Generation System

Lightning source possesses huge amount of electricity. This renewable lightning electric power generation is designed to capture lightning first time for human use. Generally during raining and thunder-storm time, lightning is a daily affair which causes casualties and natural disasters. The large number of lightning arrestors or catchers in a locality at the top of high rise buildings, trees

and structures for antenna mounting (tower) etc. are fitted. Each of the lightning arrestors is connected to a common collection resource or transducer placed at a central location by good sufficient thickness and width (gauge) conducting wire like copper or any alloy made. Generally clouds are moving in the sky with charged condition either positively charged or negatively charged. Whenever this charged cloud comes nearer to the lightning arrestor, they induce opposite charge to the lightning arrestor. Since the lightning arrestor on the top is designed like spike, the induced charge on the spike charges the surrounding air. This charged air (same type as induced in the lightning arrestor) is attracted or rushed towards the charged cloud. As the two charges are opposite, the charge on the cloud will be neutralized by the charge of the air. Since the lightning arrestor is induced charge by wait state of the charged cloud, so this charge on the lightning arrestor can be converted or stored to electrical energy as voltage and current.

Again at the time of charged cloud or lightning, the lightning arrestors catch electrical energy which is a.c. electric nature mixed with sufficient quantity d.c. also, i.e., huge amount of electricity flows through the conducting feeder wire or cable and associated circuitry. The electrical charge consisting of the charged cloud and the lightning is arrested in high duty capacitors which are shown in Fig. 8. Each capacitor is having very high capacitance range like hundreds of farad which are generally used in high tension line or power electronics circuit. Circuit diagram of charged cloud and lightning electric power generation system (plant) is designed in Fig. 9. The electrical energy captured by the lightning arrestors either at the time of charged cloud or lightning is passed through high duty rectifier circuit to convert all types of electrical energy in d.c. form. If the charged cloud or the lightning is consisting of very high voltage which are incapable of handling by the rectifier circuit, this high voltage charged cloud or lightning is grounded by the arrangement made in the rectifier circuit. Then rectifier output d.c. electric voltages are passed to the n number of capacitors, connecting parallel marked as $C_1, C_2, C_3, \dots, C_n$. If capacitor with high capacitance is not available, then a block of parallel capacitors is used instead of single capacitor for providing high equivalent capacitance. The capacitors are connected parallel due to their equivalent or total capacitance is within high value range, such that, they can accept the total charge (voltage) carrying by the charged cloud or the lightning. The total or equivalent capacitance (C_{eq}) for n number of parallel connected capacitors $C_1, C_2, C_3, \dots, C_n$ is expressed as, $C_{eq} = C_1 + C_2 + C_3 + \dots + C_n$.

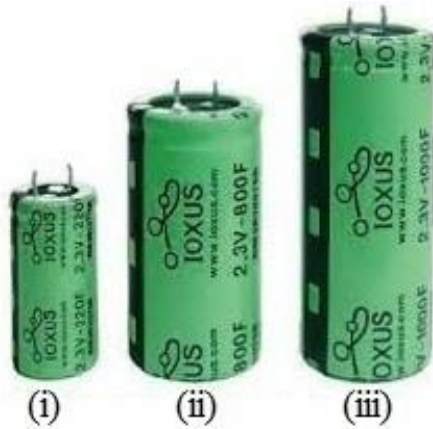

Fig. 8. (i) 220F (ii) 800F (iii) 1000F hybrid capacitors.

When the total charge (Q) is fed to the n number parallel connected capacitors, this total charge (Q) is divided among the capacitors like $Q_1, Q_2, Q_3, \dots, Q_n$. Since, $Q = C_{eq} \times V$ coulomb, where C_{eq} is a constant, here as total capacitance of the capacitors in farad, and all parallel connected capacitors will be charged up to the voltage V volt. As C_{eq} is having very high value due to all capacitors connected parallel, the voltage (V) developed across the each capacitor is within reasonable value, for that the capacitors are not damaged or burnt. If the capacitors are connected in series, the total capacitance is having very low value, and the charging voltage will be very high value; as a result they may not withstand such high voltage.

Reactance offered by a capacitor having capacitance ' C ', to an a.c. voltage of radian frequency ω rad/s is given by, $X_C = \frac{1}{\omega C}$, and the instantaneous current (i) and the instantaneous voltage (v) across a capacitor are expressed as, $i = \frac{dQ}{dt} = C \frac{dV}{dt}$, $v = \frac{1}{C} \int i dt$. In case of a d.c. voltage source, since d.c. is having very low frequency, i.e., $\omega = 0$, $X_C = \infty$ [infinity], $i = 0$, no current flows through the capacitors, only the capacitor's terminals (plates) will be charged by the applied d.c. voltage, and the maximum voltage of the capacitors may be up to the supplied d.c. voltage .

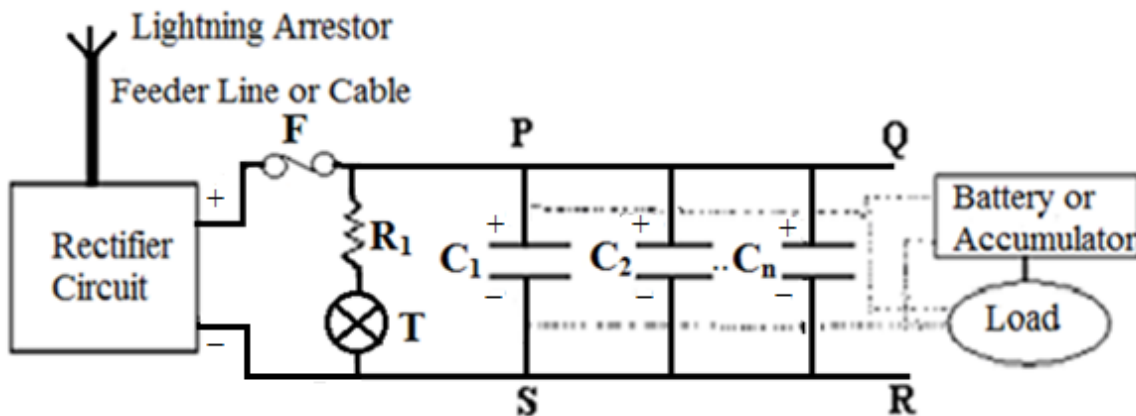

Fig. 9. Circuit diagram of Charged Cloud and Lightning electric power generation system by parallel capacitors connected parallel with a rectifier circuit.

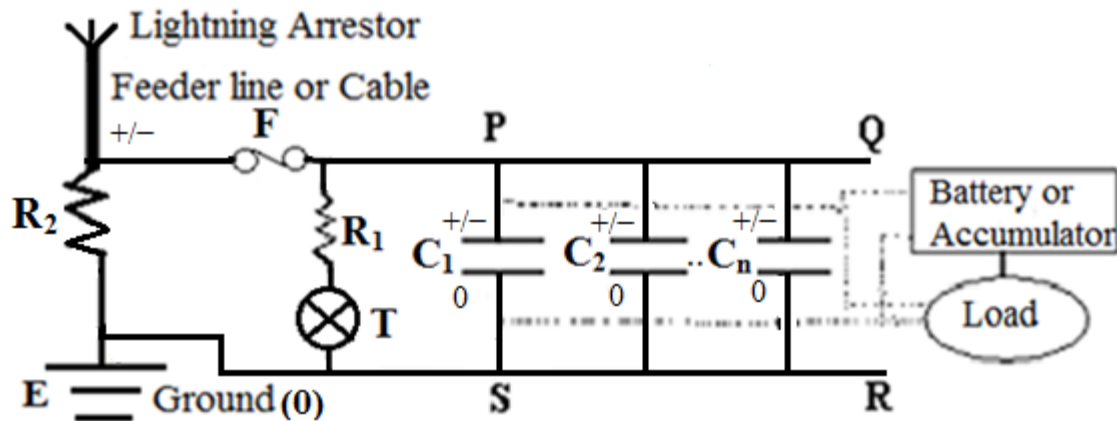

Fig. 10. Circuit diagram of Charged Cloud and Lightning electric power generation system by parallel connected capacitors directly.

If high duty rectifier is not able to manufacture or very costly, then it can be curtailed or eliminated from the lightning electricity circuit, in this case the lightning arrestors are directly fed to the parallel capacitors as shown in Fig. 10, and these parallel connected capacitors become charged to their maximum voltage.

A lamp or bell (T) fitted with resistance (R_1) indicates the presence of a charged cloud or a lightning. When the lamp or the ringer (T) activates, it means that a charged cloud or a lightning appears. After charging the capacitors, they are disconnected from the lightning arrester circuit, then this charge (voltage) on the capacitors act as electrical energy source to the connected load; or set of storage batteries like jelly filled batteries or accumulator circuit are charged by these charged capacitors for permanent storing of electrical energy or voltage, otherwise the charge on the capacitors will be leakage, i.e., discharge automatically. Hence the charged capacitors or the charged batteries or the charged accumulator circuit act as a d.c. voltage source and they can easily fed to the load as an electric power or voltage source. Again we can convert this d.c. voltage and current to a.c. voltage and current by an inverter circuit manufactured by thyristors and integrated circuit (ICs) chips as per our requirement.

In Fig. 10, the lightning arrestors are directly connected to the n number of parallel capacitors $C_1, C_2, C_3, \dots, C_n$, through fuse or circuit breaker F, the resistance R_2 is connected parallel to the capacitor's circuit such that the resistance value of R_2 is more than the total impedance (resistance) value of the capacitor's circuit. Therefore, under normal condition the charge (voltage and current) of the charged cloud or the lightning energy will pass through the parallel capacitors only, hence the capacitors will be charged to available voltage. Thereafter, these charged capacitors deliver electric power or voltage to the load or to store in the battery or the accumulator circuit. When high duty fuse or circuit breaker (F) will fire or cut due to heavy charge (voltage and current) containing in the charged cloud or the lightning, then the charged

cloud or the lightning is grounded (E) through resistance R_2 to safe guard the whole circuit as well as the surrounding medium.

8. Second Technique for Charged Cloud and Lightning Electric Power Generation System

Another procedure for deriving electricity from a charged cloud or a lightning source is achieved by any electrical power transducer circuit, i.e., converting electrical energy to the other form of energy, e.g., heat energy or mechanical energy or any other form of energy etc. Then this transformed energy like heat or mechanical or other form energy etc. is converted to electrical energy. The transducers, using for charged cloud or lightning electric power storing, convert this huge amount of electrical energy either to heat energy by suitable metal or alloy plates, e.g., nichrome (Ni-Cr) alloy, ceramic alloy, thermocouple etc. or to mechanical energy by motor, rotor etc. or to any other form of energy. Subsequently this heat energy or mechanical energy or transformed energy is converted to electrical energy acting as power resources which is delineated in Fig. 11.

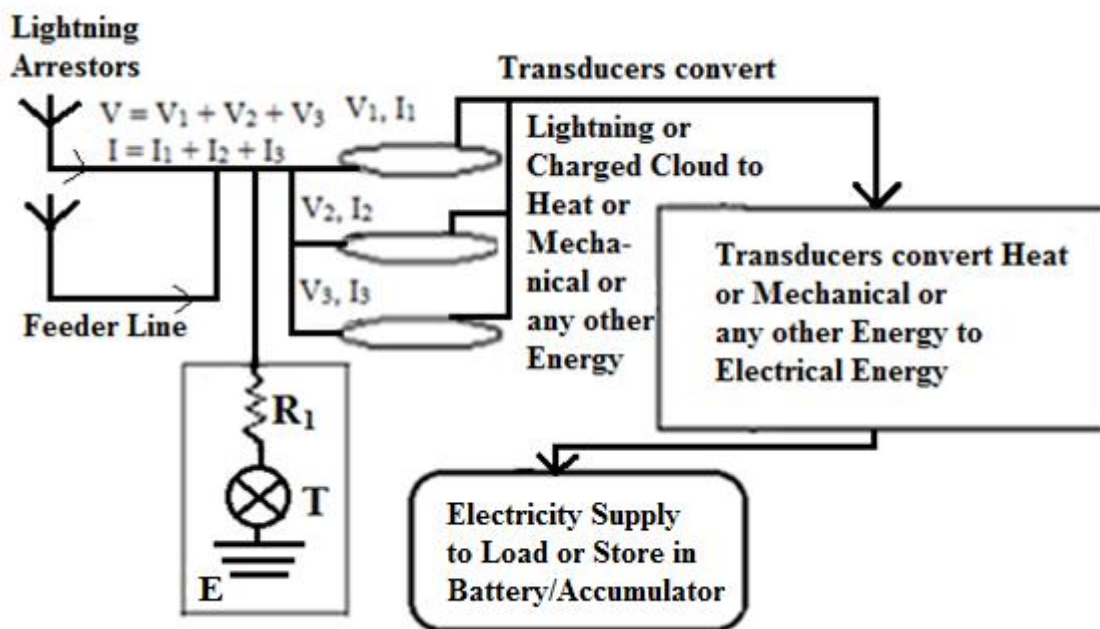

Fig. 11. Block diagram of Charged Cloud and Lightning electric power generation system with parallel plate transducers.

In Fig. 11, V and I are the total voltage and the total current received from the charged cloud or the lightning source. Then this V is subdivided into three or more voltage quantities like V_1, V_2, V_3 etc., when the transducers are connected in series, and this I is subdivided into three or more current quantities like I_1, I_2, I_3 etc., when the transducers are connected in parallel. Now these divided voltages and currents supply three or more transducer plates for converting these voltages and currents to heat or mechanical or any other energy. Thereafter, these heat or mechanical or changed energy quantities are further converted to electrical energy by suitable

transducers as shown in Fig. 11. Finally, the output electric power as derived from the charged cloud or the lightning source is employed for use in variety of purposes from domestic to commercial. T is a lightning indicator either lamp or bell type fed with very high resistance (R_1) to the rectifying or the direct output for indicating the presence of electric power in the circuit as shown in Fig. 11.

This process is done by the following procedure. Three sets of capacitors, as each set in the panel PQRS of Fig. 9 or Fig. 10, are taken. Each set of capacitors is connected with one series resistance from R_3 , R_4 , R_5 where R_3 , R_4 , R_5 may be equal or not. If the impedances of the set of capacitors connected with the respective resistances are equal, then the voltages and the currents in different sets of the capacitor circuits are same, otherwise they differ. Therefore, these sets of capacitors with the resistances tunnel the total charge (voltage and current), and accordingly they are charged. After completely charging, the charged capacitors are disconnected from the lightning arrestor circuit. Now they are discharged electrical energy to heat or mechanical or any other form of energy by the transducers arrangement, later on this heat or mechanical or any other form of energy is converted to electrical energy by another set of transducers, finally this electrical energy (electricity) is supplied either to the load or the battery for storing. For discharging the capacitors it requires some time, i.e., the rate of discharge depends on our requirement. Thus for further picking up a charged cloud or a lightning source by the same circuit, the lightning arrestors circuit is switched over to another set of fully discharged capacitors or activate transducers. Hence, the same lightning plant is safely used for frequent appearance of the charged cloud or the lightning.

9. Third Technique for Charged Cloud and Lightning Electric Power Generation System

Generally more numbers of different parallel capacitors circuits (PQRS), say 5 numbers, as designed in Fig. 12 are taken. Each parallel capacitors circuit is connected with one resistance in series from the resistors R_3 , R_4 , R_5 , R_6 and R_7 as shown in Fig. 12. Now the lightning arrestor line is connected parallel with these different sets (5 sets) of parallel capacitors in which each set is connected one resistance in series from R_3 , R_4 , R_5 , R_6 and R_7 respectively.

The lightning arrestor line is directly connected to ground through resistance R_2 which is parallel to the each set of capacitors. The resistance value of the connecting resistors R_2 to R_7 are chosen as $R_2 > R_3 > R_4 > R_5 > R_6 > R_7$; so that, R_2 has the highest resistance value and R_7 has the lowest resistance value. The parallel capacitors used in each set of circuits are equal number and same type. Therefore, the impedance of each set of capacitors is constant, i.e., same with the other set of capacitors. When each set of capacitors is connected to one resistance in series like R_3 or R_4 or R_5 or R_6 or R_7 , the difference of the impedances among the sets of capacitors are equal to the difference of the corresponding resistances connected to the sets of capacitors. Therefore, the charged cloud or the lightning carrying electrical energy (voltage and current) always seek less impedance or resistive path to pass through a circuit. Normally maximum charge (voltage and

current) will go through R_3 to R_7 connected capacitors circuits, provided these capacitors circuits are in good workable condition.

When all the capacitors circuits connecting by R_3 , R_4 , R_5 , R_6 and R_7 respectively are disconnected from the lightning arrester by operation of their respective fuses or the circuit breakers (F) due to consisting of very high electric charge in the charged cloud or the lightning, that very high charge (voltage and current) is safely grounded through resistance R_2 . The resistances R_3 , R_4 , R_5 , R_6 and R_7 are selected such as they are comfortable for the fuses or the circuit breakers for safe guard the circuit.

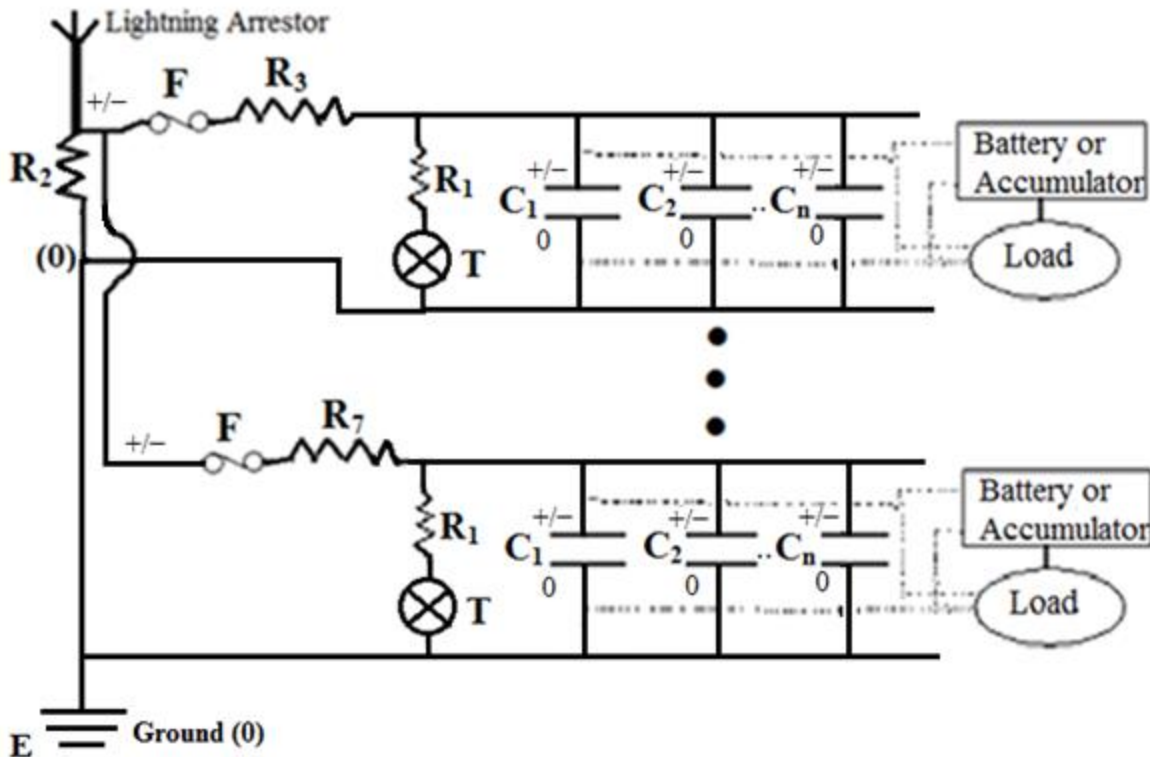

Fig. 12. Circuit diagram of Charged Cloud and Lightning electric power generation system by different sets of parallel connected capacitors with changing impedance values.

After being fully charged, the charged capacitors are separated from the lightning circuit. Then the charged capacitors are either connected to the load directly or to the charging circuit of the batteries or the accumulator circuit for permanent storing the electrical charge or voltage.

10. Fourth Technique for Charged Cloud and Lightning Electric Power Generation System

In this technique, the lightning arrestors with the capacitors circuits are fitted on the solar panels using in rural and urban areas which is shown in Fig. 13.

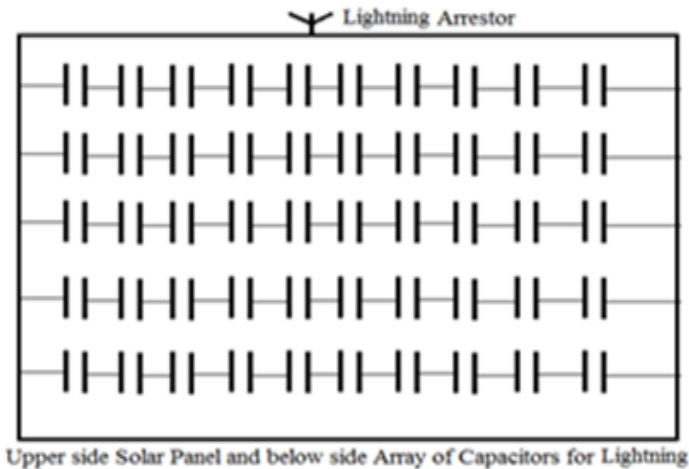

Fig. 13. Charged Cloud and Lightning electric power generation system installed in the solar panel.

The parallel sets of capacitors are kept below the solar panel such that in case of picking a charged cloud or a lightning, the capacitors become charged. After charging the capacitors, the capacitors are discharged either through the same solar circuit or separate discharging circuit, since during the charged cloud or the lightning time generally the solar system is not working. Therefore, we do not construct separate network to supply the electrical energy to the load or store in the battery for a charged cloud or a lightning appearance.

The normal electric supply transmission network or power grid line with a stipulated distance can be applied to bring the charged cloud or the lightning energy to the lightning plant located at a central place. Hence it covers a huge area for capturing charged cloud or lightning energy. This high tension commercial electric power supply line can be used as lightning arrestor after disconnecting from the commercial generators and transformers, especially in cloudy rainy and thunder-storm times, when a charged cloud and a lightning is highly predicted. Then the charged cloud or the lightning can be captured by the lightning arrestors fitted on the transmission lines, and this charged cloud or lightning energy charges the sets of capacitors connected parallel to each other. Hence, the above described electrical power generation techniques from the charged cloud or the lightning produce reliable good amount of electricity.

11. Thunder Electric Power Generation System

After each lightning, nearby areas are trembled or jerked with deep sound called thunder. This high intensity thunder energy can be converted to electricity (voltage and current) using suitable transducer. Now-a-days piezoelectric crystals are more popular to convert sound energy to electrical energy. When this piezoelectric crystals are subjected to pressure or force on the two opposite faces, positive and negative electric charges (potential difference or voltage) are produced on these two opposite faces; the signs of these charges (voltage) are reversed if the pressure is replaced by tension. If such piezoelectric crystals are subjected to an electric potential, an alteration in size of the crystals is taking place. Thus the pressure on the opposite two faces of a piezoelectric crystal is increased; electrical voltage develops on the faces. Since a piezoelectric crystal is able to offer very low voltage while stressed or pressurized, so lot of piezoelectric crystals are used to store thunder energy from a lightning.

These huge numbers of piezoelectric crystals are connected in series, i.e., positive voltage terminal of one crystal is connected to negative voltage terminal of other crystal, such that, the total available voltage is the sum of all individual voltages offering by the piezoelectric crystals. Therefore, by using piezoelectric crystals with diaphragms which activate pressure on the piezoelectric crystals, we can have good amount of electricity from a thunder. This electrical energy derived from the thunder is either fed to the load or storing in the battery or the accumulator circuit.

12. Solar, Rains, Wind, Charged Cloud, Lightning, Thundering Energies – Integrating Electrical Power Generation System

To eliminate the drawbacks of individual renewable power generation system derived from solar or rains or wind or charged cloud or lightning or thunder energy, a new electrical power generating system by integrating all the renewable power sources available from natural resources simultaneously is designed, so that, power supply remains continuous without any sort of interruptions or load shedding.

This integrating solar-rains-wind-charged cloud-lightning-thunder energies electrical power generation system can offer requisite amount of power suitable for household as well as commercial purposes in all times. Thus we have not to depend on certain environmental (natural) condition, i.e., the sun or the rains or the wind speed or the charged cloud or the lightning or the thunder appearance at all.

13. Integrating Solar-Rains-Wind-Charged Cloud-Lightning-Thunder Energies Electrical Power Generation System

We see, if the sun does not appear throughout a day or appear for lesser time in a day, then the probability of appearing rains with charged cloud, lightning and thunder are too much high in that day. Most of the cases the rains fall in that day with or without lightning and thunder

obviously. Therefore, we consider that there are two conditions of environment in a day, i.e., either the sunny times or the rainy times. Also in the rainy times, generally wind flow, i.e., speed of the wind is increased and probability of the charged cloud or the lightning is higher. Therefore these six natural non-conventional sources are intelligently used for electrical power generation. So, all the resources in the nature like solar, rains, wind, charged cloud, lightning and thunder energies are integrated in a unique way. This is done first time. Generally at present solar power system, full charged battery or storage circuit cannot supply the requisite power to the load more than two consecutive days, then these two conditions, i.e., the sunny time or the rainy time will appear in major time period and in between these two conditions, cloudy time remains very short period, i.e., cloudy time (when there is no sun or no rains) may be overlooked in a day. If we able to supply electricity to the load or charge the battery or store electrical power during the rainy times, we have the power sources without interruptions. This is done by integrating several renewable energies as delineated in Fig. 14.

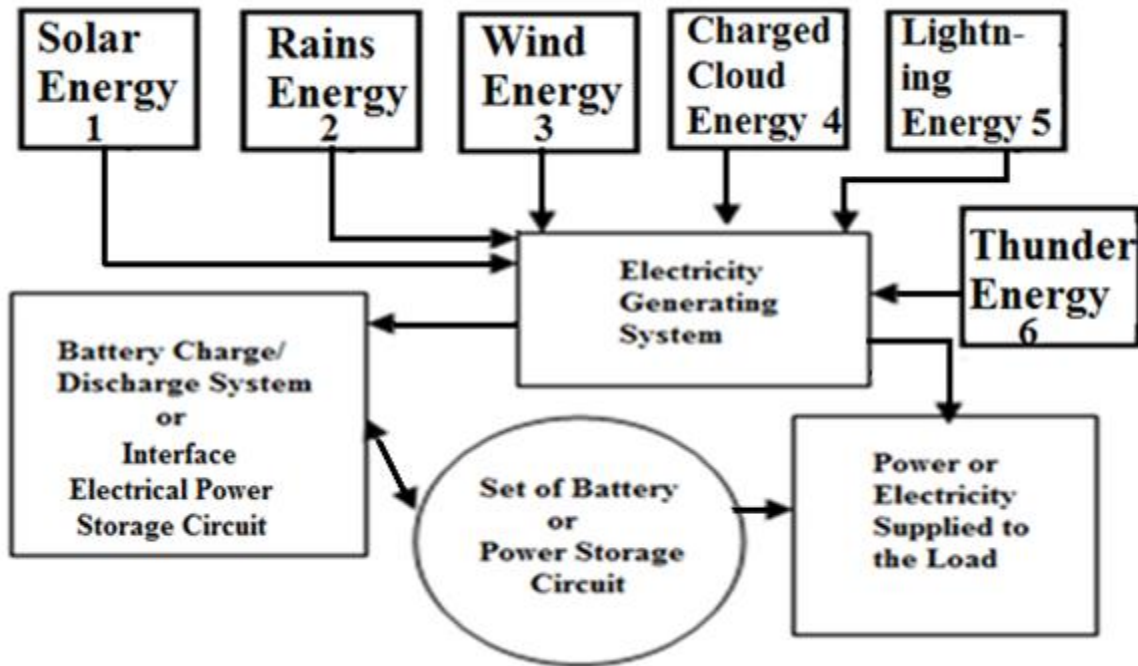

Fig. 14. Electrical power generation system integrating Solar-Rains-Wind-Charged Cloud-Lightning-Thunder energy sources.

Similar to the construction of individual non-conventional power system as described above, this integrating solar-rains-wind-charged cloud-lightning-thunder electric power generation system is designed as shown in Fig. 14. The only difference is that it has some special equipment to charge the battery or the power storage (accumulator) circuit by solar, rains, wind, charged cloud, lightning, thunder etc. This is clearly described in the block diagram of Fig. 14. Control circuit ad-joint with electric power generating system provides necessary control functions such as adding or summing up electric power obtained from more than one sources at a time, i.e., solar-

wind electric power systems simultaneously, rains-wind electric power systems simultaneously, rains-wind-lightning-thunder electric power systems simultaneously etc., over voltage protection, amount of electric power directed to the load and the battery.

Thus by implementing solar-rains-wind-charged cloud-lightning-thunder energies integrating electrical power generation system in a compact package, we have an uninterrupted power supply at the minimum cost to all places at all times (24×7). Moreover, we can avoid accidental risk and effect by a lightning to human and nature both.

This method ensures a highly practical oriented pollution free and accident free inventory for electrical power generation system. The electrical power afforded by this system is completely pure and secured form without any sort of environmental pollution. Also it does not produce any greenhouse effect or acid rain or emit any kind of poisonous gases or electromagnetic radiation and nuclear radiation etc.

14. Advantages of Integrating Solar-Rains-Wind-Charged Cloud-Lightning-Thunder Energies Electrical Power Generation System

This integrating renewable energies power generation system has following advantages,

- (i) This integrating solar-rains-wind-charged cloud-lightning-thunder energies electrical power generation system will be highly effective in all places, especially in rural areas where the commercial electricity has not reached or undelivered.
- (ii) It causes no side or bad effect on nature (emits no carbon or radiation), i.e., absolute pollution free.
- (iii) At the same time it is not prone to any kind of accident due to lightning, i.e., natural disasters are avoided.
- (iv) It is highly suitable for domestic as well as commercial purposes. It is also useful to urban and city areas, simultaneously with the commercial power supply to minimize power supply load, i.e., cut short power charge.
- (v) By using this integrating power generation system, people can save electricity charge.
- (vi) Also it has very less maintenance charge which is required for this power system. No raw materials are exhausted. Thus using this system, electricity cost per unit is a small amount.
- (vii) The designing of this equipment is done in such a way that it is very compact and acts as user friendly.
- (viii) When it will be manufactured in a large commercial scale, cost of this integrated natural resources renewable electrical power generation system is affordable to all.
- (ix) Moreover, there is no electric power failure or load shedding situation at any times. Therefore, it is the most reliable renewable electrical power resources with the least expenditure in the earth.

References

- [1] P. K. Bhattacharjee, "Solar-Rains-Wind-Lightning Energy Source Power Generation System", International Journal of Computer and Electrical Engineering (IJCEE), Singapore, vol. 2, no. 2, pp. 368-371, ISSN No. 1793-8163, April 2010 (incorporating Wikipedia Harvesting Energy site).
- [2] P. K. Bhattacharjee, "Solar, Rains, Wind, Charged Cloud, Lightning, Thunder Energies – Integrating Electrical Power Generation System", International Journal of Scientific Research in Science, Engineering and Technology (IJSRSET), India, vol. 1, issue 5, pp. 177-186, ISSN No. 2395-1990, Sept-Oct 2015.
- [3] C. Hanley, M. Ross, R. Foster, L. Estrada, G. Cisneros, C. Rovero, L. Ojinaga, A. Verani, "Using Renewable Energy for Rural Connectivity and Distance Education in Latin America", 29th IEEE Photovoltaic Specialists Conference, New Orleans, May 2002.
- [4] Bill Williams, "Solar and Other Renewable Energy Technologies", 2002.
- [5] H. Cotton, "Advanced Electrical Technology", Wheeler Publishing, New Delhi, 1997.
- [6] K. S. V. Santhanam, M. Sharon, "Photoelectrochemical Solar Cells", Elsevier Science, Amsterdam, 1988.
- [7] F. C. Treble, "Generating Electricity from the Sun", Pergamon Press, Oxford, England, 1991.
- [8] G. Willeke, G. Grassi, "Photovoltaic Power Generation", D. Reidel Publishing Co, Holland, 1987.
- [9] M. R. Patel, "Wind and Solar Power Systems", CRC Press, Florida, 1999.
- [10] H. P. Garg, J. Prakash, "Solar Energy Fundamentals and Applications", 1st Edition, Tata McGraw-Hill Publishing Company Ltd, New Delhi, 2002.
- [11] L. Monition, M. L. Nir, J. Roux, "Microhydroelectric Power Stations", John Wiley & Sons, Paris, 1984.
- [12] P. K. Nag, "Power Plant Engineering", 2nd Edition, Tata McGraw-Hill Publishing Company Ltd, New Delhi, 2005.