



# **iJRASET**

International Journal For Research in  
Applied Science and Engineering Technology



---

# **INTERNATIONAL JOURNAL FOR RESEARCH**

IN APPLIED SCIENCE & ENGINEERING TECHNOLOGY

---

**Volume: 9      Issue: 1      Month of publication: January 2021**

**DOI: <https://doi.org/10.22214/ijraset.2021.32853>**

**[www.ijraset.com](http://www.ijraset.com)**

**Call:  08813907089**

**E-mail ID: [ijraset@gmail.com](mailto:ijraset@gmail.com)**

# Performance Analysis and Result of D-STATCOM for Improvement of Power Quality

Radhika Bihade<sup>1</sup>, Prof. K. K. Rajput<sup>2</sup>, Dr. S. B. Mohod<sup>3</sup>

<sup>1</sup>Department of Electrical Engineering, PLITMS Buldhana, Maharashtra, India

<sup>2</sup>Assistant Professor, Department of Electrical Engineering, PLITMS Buldhana, Maharashtra, India

<sup>3</sup>Assistant Professor, Department of Electrical Engineering, PRMCEAM Badnera, Maharashtra, India

**Abstract:** *This paper gives the Performance Analysis and Result of D-STATCOM for Improvement of Power Quality using Matlab software. It gives the simulation MATLAB results about the work that has been done. The MAT-LAB simulation modules are useful for the actual design of the proposed work. MATLAB software is used due to its extensive scope of application in research and analysis zone. MATLAB software is used to simulate whole system. This software allows assembling the circuit, running the simulation, analysing the results, and managing the data in a completely integrated graphical environment. This dissertation is focus on the synchronization of the inverter with grid using dq-PLL method. . It gives the results about the voltage and current characteristics of the inverter and grid. It describes about the voltage magnitude of inverter and grid. It also gives the values of active and reactive power.*

**Keywords:** MATLAB, PLL method, D- STATCOM

## I. INTRODUCTION

Power quality problems in the distribution system can be mitigated using different techniques and the group of devices is known as custom power devices (CPDs) which include the DSTATCOM (distribution static compensator), DVR (dynamic voltage restorer) and UPQC (unified power quality conditioner) are used for compensating the power quality problems in the current, voltage and both current and voltage respectively.

The DSTATCOM is a shunt-connected device which takes care of the power quality problems in the load currents. There are different topologies for three-phase four-wire DSTATCOM, out of which a DSTATCOM with PWM switched VSC along with a zig-zag transformer is used for compensating power quality problems in the supply currents. The application of a zig-zag transformer for reduction of the neutral current is having an advantage due to passive compensation, rugged and less complex over the active compensation techniques. The new application of a zig-zag transformer is to connect in parallel to the load for filtering the zero-sequence components of the load currents. SVPWM technique offers several advantages like higher output voltage (15% more than conventional sine-triangle modulation technique and hence, better utilization of DC link), lower harmonics etc.

### A. Objectives

The most important objective of present work is to design and simulation of VSC based DSTATCOM and zig-zag transformer for the compensation of power quality problems to make the distribution system more efficient using MATLAB software.

## II. METHODOLOGY

MATLAB is a high-performance language for technical computing. It integrates computation, visualization, and programming in an easy-to-use environment where problems and solutions are expressed in familiar mathematical notation. Typical uses include: Math and computation Algorithm development modelling, simulation, and prototyping Data analysis, exploration, and visualization Scientific and engineering graphics Application development, including Graphical User Interface building MATLAB is an interactive system whose basic data element is an array that does not require dimensioning. This allows us to solve many technical computing problems, especially those with matrix and vector formulations, in a fraction of the time it would take to write a program in a scalar non interactive language such as C or Fortran. The name MATLAB stands for matrix laboratory. MATLAB was originally written to provide easy access to matrix software developed by the LINPACK and EISPACK projects, which together represent the state-of-the-art in software for ma-trix computation. MATLAB has evolved over a period of years with input from many users. In university environments, it is the standard instructional tool for introductory and advanced courses in mathematics, engineering, and science. In industry, MATLAB is the tool of choice for high-productivity research, development, and analysis. MATLAB features a family of application-specific solutions called toolboxes.

Very important to most users of MATLAB, toolboxes allow you to learn and apply specialized technology. Toolboxes are comprehensive collections of MATLAB functions (M-files) that extend the MATLAB environment to solve particular classes of problems. Areas in which toolboxes are available include signal processing, control systems, neural networks, fuzzy logic, wavelets, simulation, and many others.

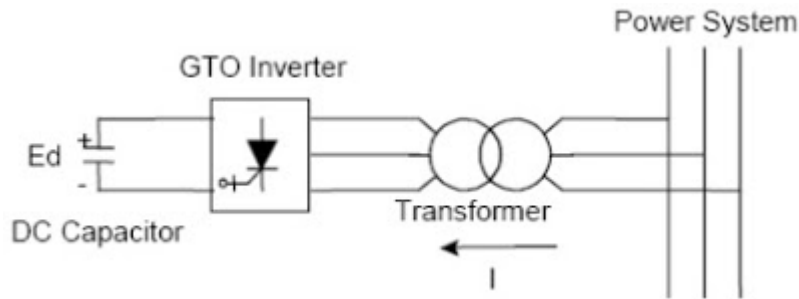

Fig: GTO-based STATCOM Simple Diagram

In the case of two AC sources, which have the same frequency and are connected through a series reactance, the power flows will be:

- 1) Active or Real Power flows from the leading source to the lagging source.
- 2) Reactive Power flows from the higher to the lower voltage magnitude source.

Consequently, the phase angle difference between the sources decides the active power flow, while the voltage magnitude difference between the sources determines the reactive power flow. Based on this principle, a STATCOM can be used to regulate the reactive power flow by changing the output voltage of the voltage-source converter with respect to the system voltage. The basic modes of operation of STATCOM are as follows –

#### A. Voltage Regulation

The static synchronous compensator regulates voltage at its connection point by controlling the amount of reactive power that is absorbed from or injected into the power system through a voltage-source converter. In steady-state operation, the voltage  $V_2$  generated by the VSC through the DC capacitor is in phase with the system voltage  $V_1$  ( $\delta=0$ ), so that only reactive power ( $Q$ ) is flowing ( $P=0$ ).

- 1) When system voltage is high, the STATCOM will absorb reactive power (inductive behavior)
- 2) When system voltage is low, the STATCOM will generate and inject reactive power into the system (capacitive).

#### B. Var Control

In this mode, the STATCOM reactive power output is kept constant independent of other system parameter.

### III. CONTROL TECHNIQUE USE FOR DSTACOM

There are several PWM techniques available for giving switching pulses to VSI. Among other techniques, the Sinusoidal Pulse Width Modulation (SPWM) is used in this design since it can directly control the inverter output voltage and output frequency according to the sine functions. The voltage source inverter should be controlled in such a way as to generate the voltages which are same as the reference voltages generated by the detection and control block. There are many theories available for the generation of reference source currents for the control of VSC of DSTATCOM for three phase four wire system viz. instantaneous reactive power theory (p-q theory), synchronous reference frame theory, power balance theory etc The synchronous reference frame theory based method is used for the control of two-leg DSTATCOM. The load currents ( $I$ ), the PCC voltages ( $v_s$ ) and dc bus voltage ( $V_{dc}$ ) of DSTATCOM are sensed as feedback signals. The loads currents in the three-phases are converted into the d-q-O frame using the Park's transformation as in eqn.

$$\begin{bmatrix} i_d \\ i_q \\ i_o \end{bmatrix} = \frac{2}{3} \begin{bmatrix} \cos \theta & -\sin \theta & \frac{1}{2} \\ \cos\left(\theta - \frac{2\pi}{3}\right) & -\sin\left(\theta - \frac{2\pi}{3}\right) & \frac{1}{2} \\ \cos\left(\theta + \frac{2\pi}{3}\right) & \sin\left(\theta + \frac{2\pi}{3}\right) & \frac{1}{2} \end{bmatrix} \begin{bmatrix} i_{ia} \\ i_{ib} \\ i_{ic} \end{bmatrix}$$

A three-phase PLL (phase locked loop) is used to synchronise these signals with the voltages at PCC. The d-q components are then passed through low pass filters to extract the DC components of  $i_d$  and  $i_q$ . The error between the reference DC capacitor voltages and the sensed DC bus voltage of both capacitors of DSTATCOM is given to a PI (proportional-integral) controller which output is considered as the loss component of the current and is added to the dc component of  $i_d$ . The error between the dc capacitor voltages difference and its reference zero value is given to another PI controller which output is added also to the dc component of  $i_d$ . Similarly, a third PI controller is used to regulate the load terminal voltage. The amplitude of the load terminal voltage and its reference value are fed to a PI controller and the output of PI controller is added with the dc component of  $i_q$ . The control strategy is to regulate the terminal voltage,

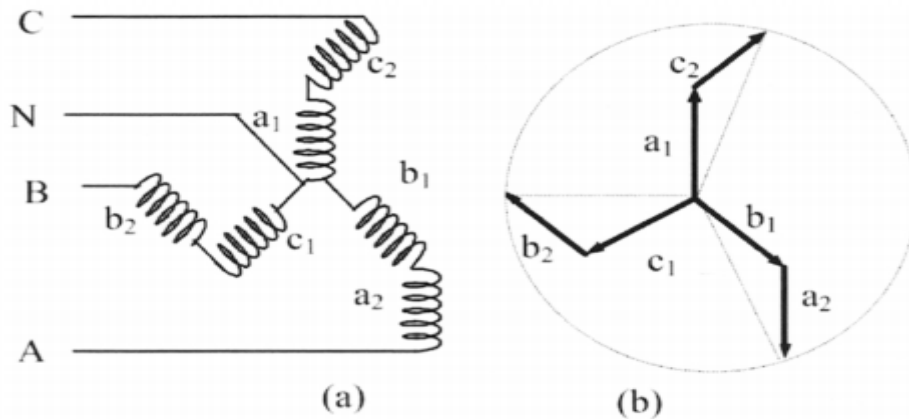

Fig: zigzag connection of isolation transformer winding b.Phasor Diagram

#### IV.SIMULATION MODEL IN MATLAB

Simulation of the complete system that is the power electronics interface of renewable energy with grid and the control methodology is done using Simulink. The Dstatcom design to improve power quality. To remove high frequency switching components from the inverter output LC filter is used. The filtered output of inverter is completely compensated and send to PCC of Line.. source is using a three phase programmable source available in Simulink Sim power library. Phase locked loop and dq current controller using PI controller are also implemented in Simulink. The system parameters used in simulation are given in Table 1

Table 1: Simulation Parameters

Sr.No.	Parameters	Value
1	Three phase peak voltage	330V
2	Grid voltage	230V
3	DC supply	650V
4	Supply frequency $f_s$	50HZ
5	Filter Inductance $L_f$	3mH
6	Inductor internal resistance $r_f$	0.05Ω
7	Filter capacitance	30μF
8	Capacitor resistance	0.5Ω
9	Load 1	R=30Ω, L=75mH
10	Load 2	R=10.29Ω, L=25.86mH

Figure shows the MATLAB Simulink model of grid tied inverter. The two-leg VSC based DSTATCOM and the zigzag transformer connected to a three phase four wire system shown in Fig.2 is modelled and simulated using the MATLAB and its Simulink and Power System Blockset toolboxes. The load considered is a lagging power factor load. The ripple filter is connected to the VSC of the DSTATCOM for filtering the ripple in the terminal voltage.

Discrete,  
Ts = 5e-06 s.  
powergui

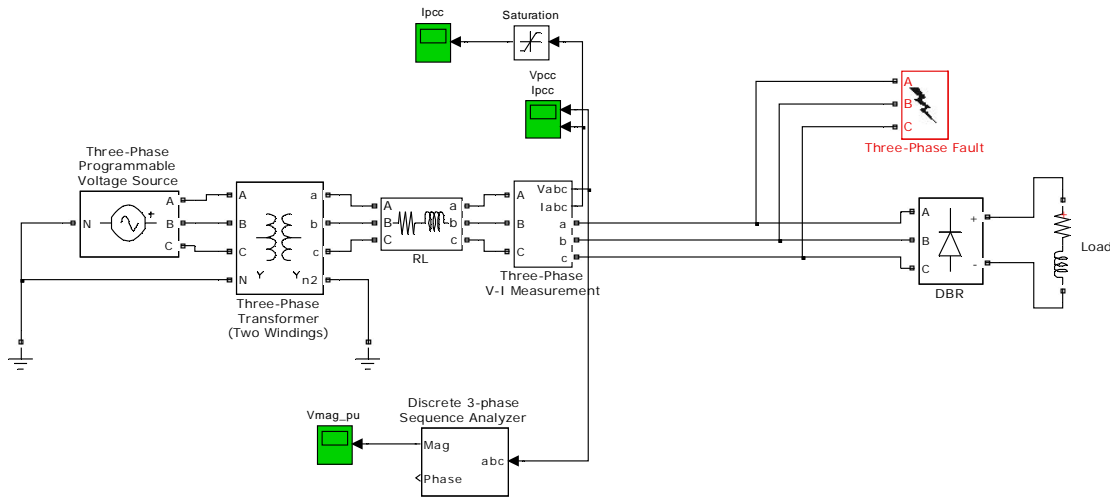
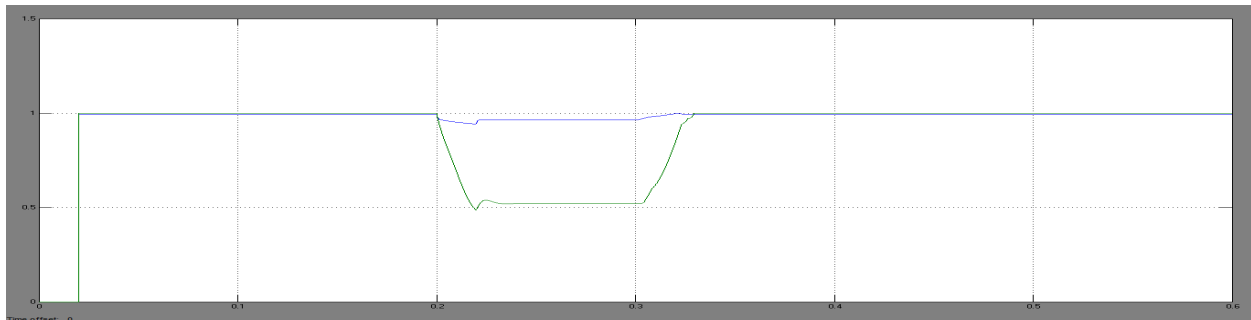

Fig :system diagram without D-statcom

### V. RESULTS & PERFORMANCE ANALYSIS

The MATLAB simulation modules are useful for the actual design of the proposed work. MATLAB software is used due to its extensive scope of application in research and analysis zone. MATLAB software is used to simulate whole system. This software allows assembling the circuit, running the simulation, analysing the results, and managing the data in a completely integrated graphical environment. This dissertation is focus on the synchronization of the inverter with grid using dq-PLL method. . It gives the results about the voltage and current characteristics of the inverter and grid. It describes about the voltage magnitude of inverter and grid. It also gives the values of active and reactive power.

#### A. Comparison of Magnitude of Voltages With And Without D-Statcom



#### B. THD of Ipcc without d-statcom

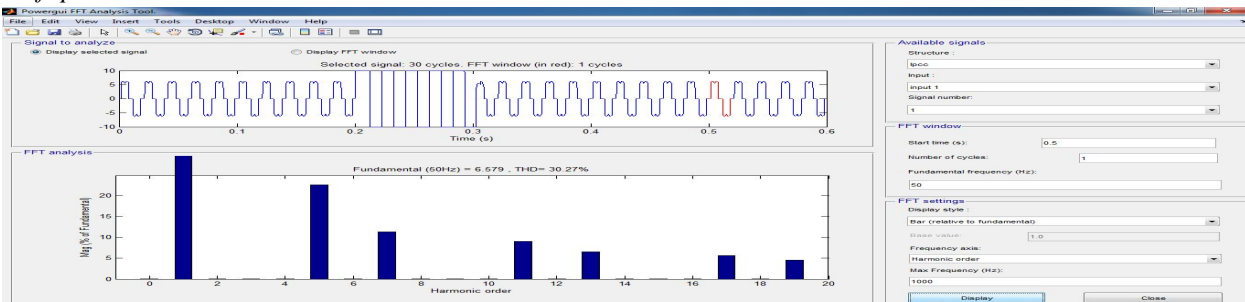

**C. THD of  $I_{pcc}$  with  $d$ -statcom**

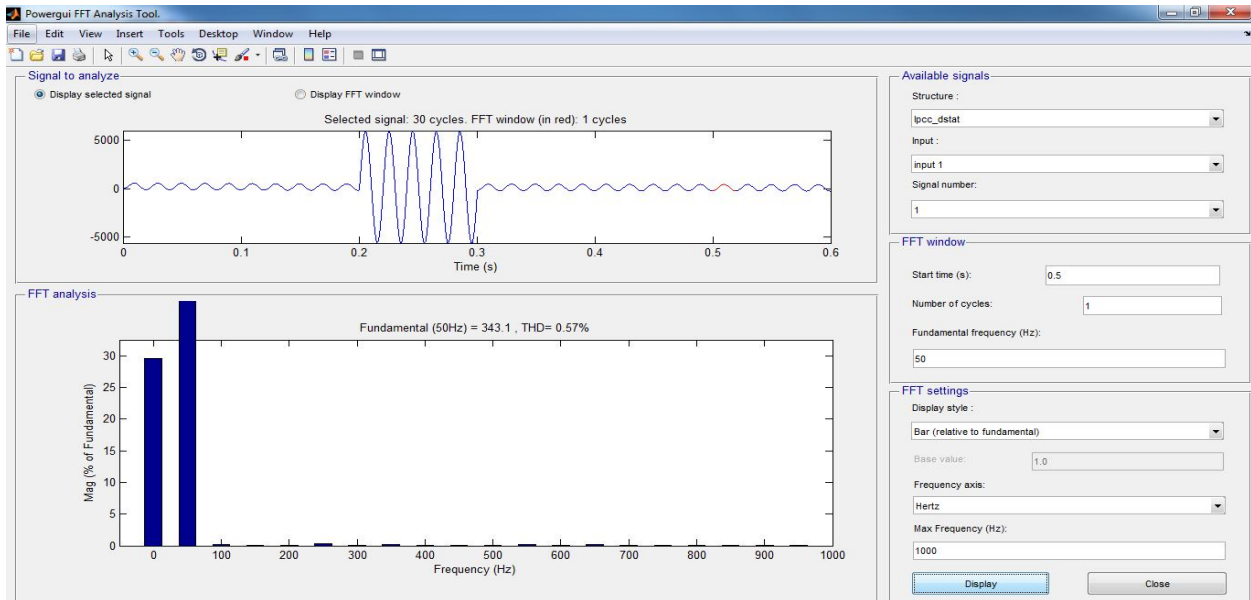

**D. Comparison of  $V_{pu}$  Magnitude with zig zag Transformer**

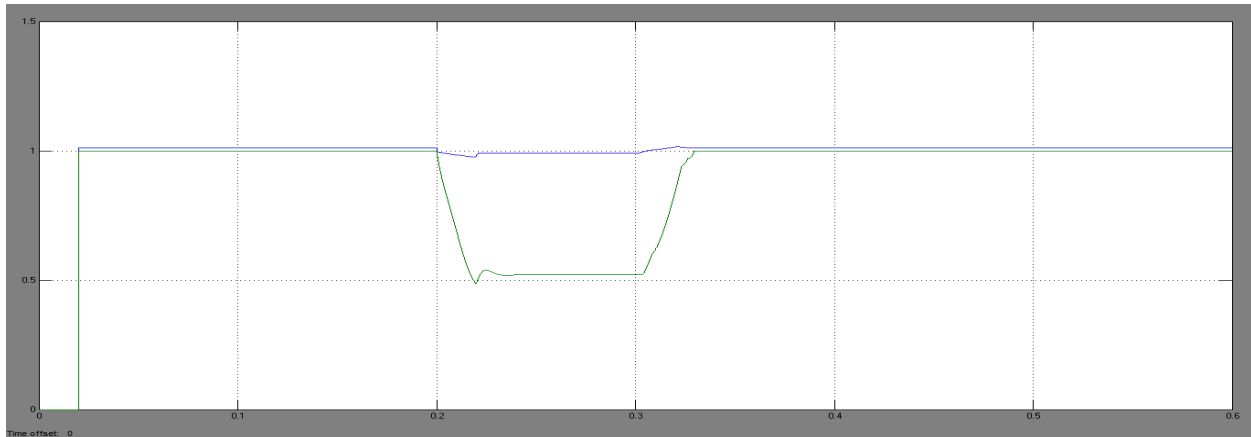

**E. Neutral Current with zig zag Transformer**

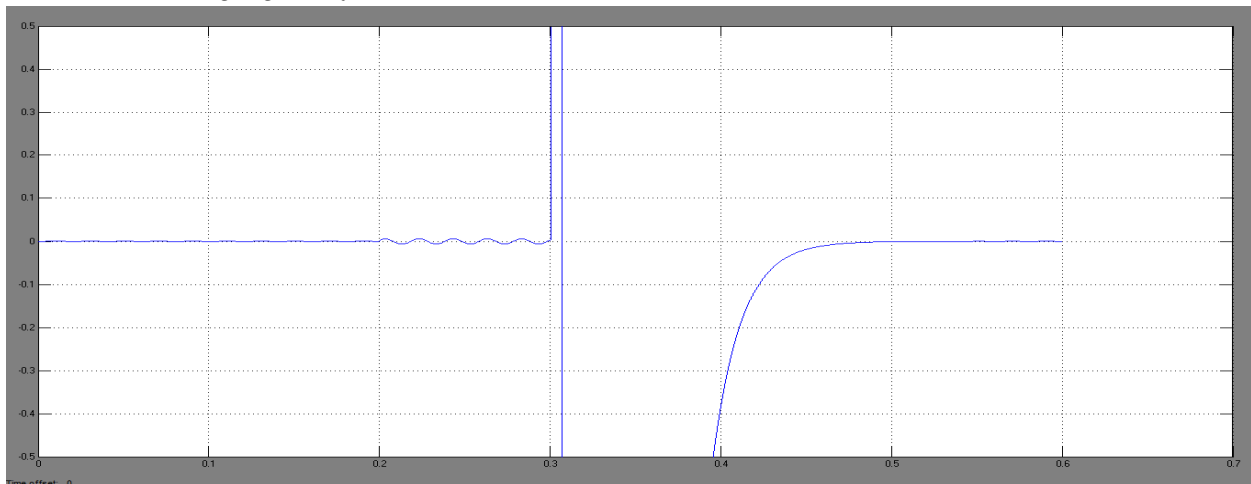

**F. THD of  $I_{pcc}$  with zig zag TF**

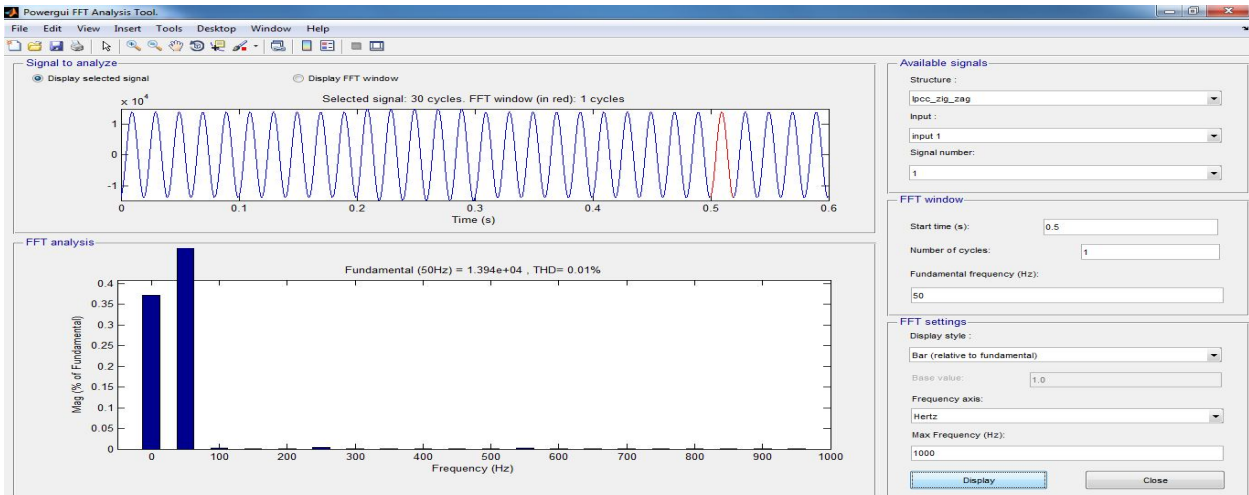

**G. Three Phase Voltage and Current without d-statcom**

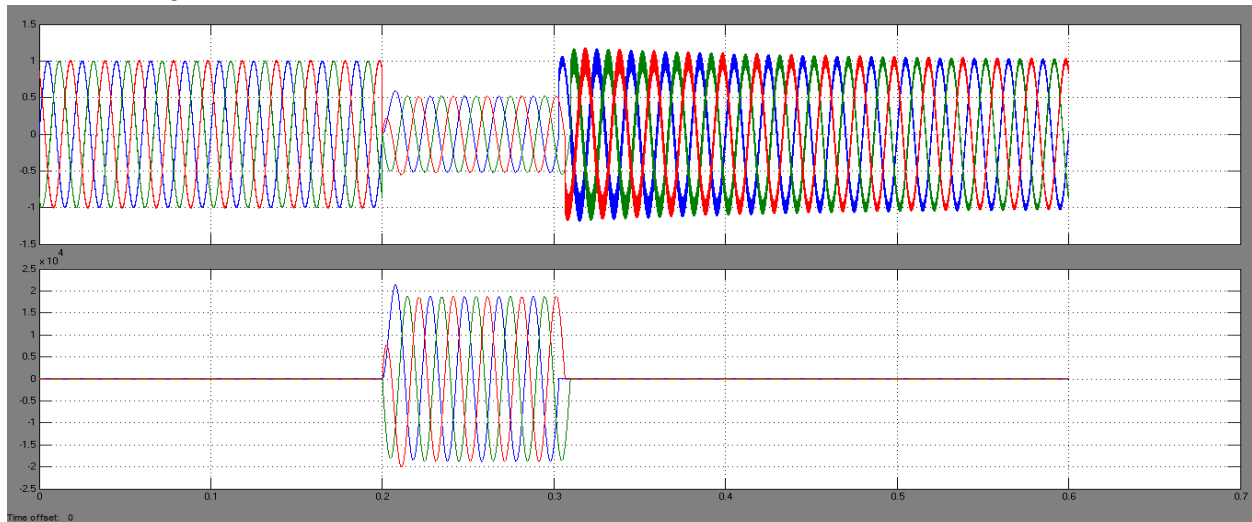

**H. Three Phase Voltage and Current with d-statcom**

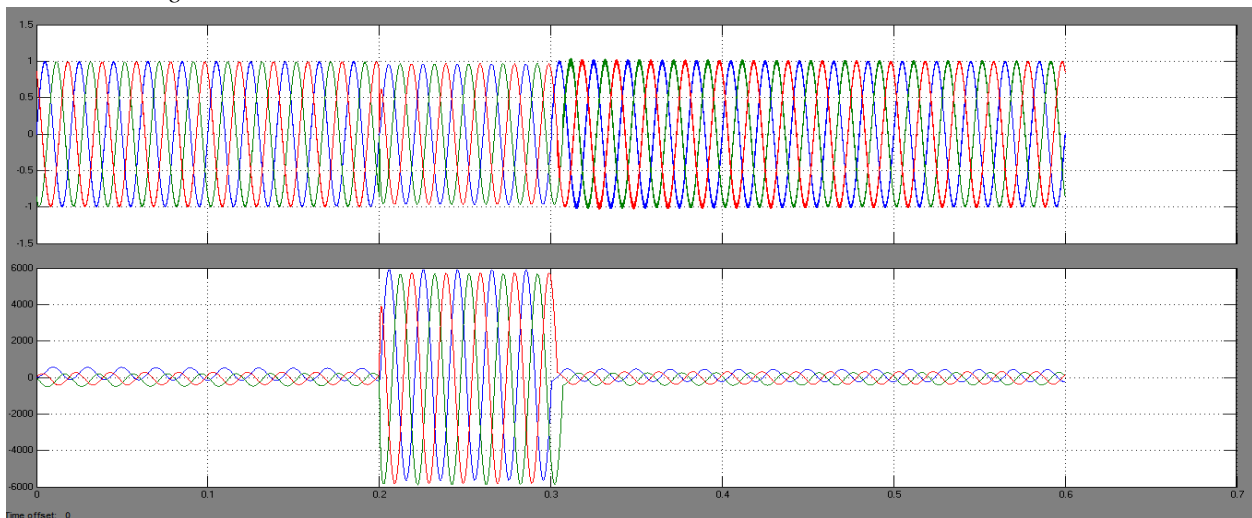

**I. Three Phase Voltage and Current with d-statcom zig zag TF**

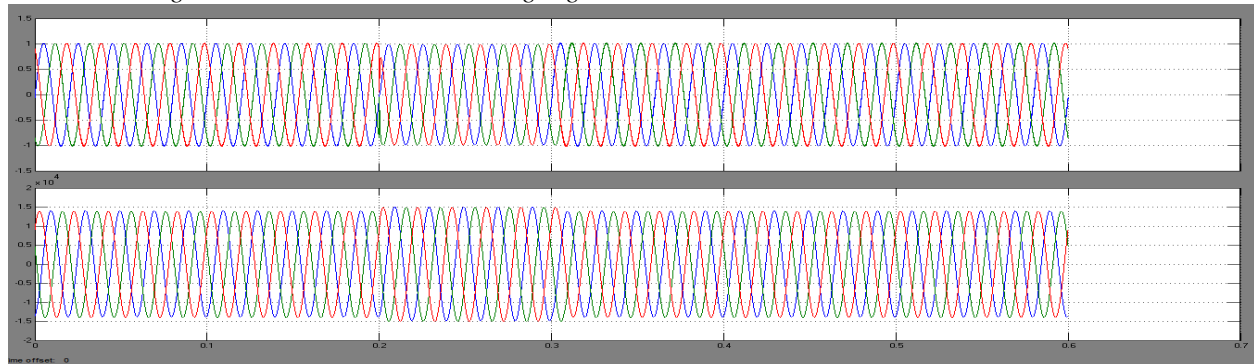

**J. Neutral Current without zig zag TF**

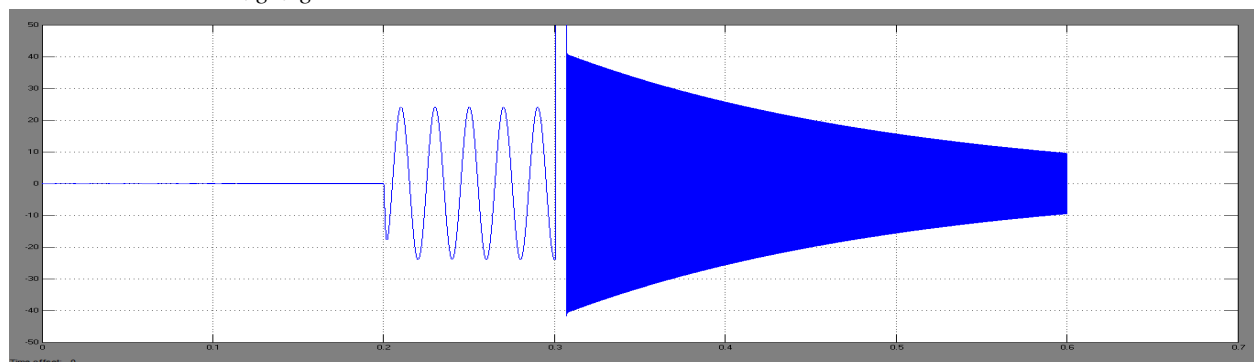

**VI.CONCLUSION**

The causes, standards, and mitigation techniques of the excessive neutral current have been investigated in the three-phase four-wire distribution system. The modelling and simulation of the zig-zag transformer has been demonstrated for neutral current compensation. Moreover, a hybrid of zig-zag transformer with a three-phase three-leg DSTATCOM has been observed as an effective option for overall compensation. The performance of the proposed compensator is validated through extensive computer simulation.

All simulation results and analysis confirmed that the output voltages of the SPWM controlled grid tied inverter are balanced with the grid and grid synchronization is successfully achieved. The low dynamic designed dq-PLL and adaptive PLL prove to overcome all the test conditions. These make them suitable for grid connected applications, such as wind turbines, PV or fuel cell systems.

**REFERENCES**

- [1] Onkar Vitthal Kulkarni, Mahesh K. Mishra Senior Member, IEEE Department of Electrical Engineering, Indian Institute of Technology Madras, Chennai, India, "Power Quality Improvement Using Zig-Zag Transformer and DSTATCOM in Three Phase Power Distribution System", Annual IEEE India Conference (INDICON), 2013
- [2] B. Singh, P. Jayaprakash, T. R. Somayajulu, and D. Kothari, "Reduced Rating VSC with a Zig-Zag Transformer for Current Compensation in a Three-Phase Four-Wire Distribution System", IEEE Transactions on Power Delivery, vol. 24, no.1, pp.249-259, 2009.
- [3] Bhim Singh, P. Jayaprakash, T. R. Somayajulu, D. P. Kothari, "DSTATCOM with Reduced Switches Using Two-Leg VSC and a Zig-Zag Transformer for Power Quality Improvement in Three-Phase Four-Wire Distribution System", IEEE Region 10 Conference (TENCON), 2008
- [4] Bishnu P. Muni, S. Eswar Rao, and JVR Vithal, "SVPWM Switched DSTATCOM for Power Factor and Voltage Sag Compensation", International Conference on Power Electronics, Drives and Energy Systems, 2006. PEDES '06.
- [5] B. Shivashankar, B. Satyavani, "Neutral current compensation using Zig-Zag Transformer with D-Statcom", International Journal of Mathematical Sciences, Technology and Humanities, 113 (2014) 1221-1227
- [6] Dorin O. Neacsu, "Space Vector Modulation - An Introduction", IECON'01: The 27th Annual Conference of the IEEE Industrial Electronics Society, 2001
- [7] Nisha G. K., Member, IAENG, Ushakumari S. and Lakaparampil Z. V., "Harmonic Elimination of Space Vector Modulated Three Phase Inverter", Proceedings of the International





10.22214/IJRASET



45.98



IMPACT FACTOR:  
7.129



IMPACT FACTOR:  
7.429



# INTERNATIONAL JOURNAL FOR RESEARCH

IN APPLIED SCIENCE & ENGINEERING TECHNOLOGY

Call : 08813907089  (24\*7 Support on Whatsapp)